**User's
Manual**

YEW SERIES 80

**Model SDAU (Style R)
Digital Alarm Unit**

IM 01B04K03-02E

Model SDAU (Style R) Digital Alarm Unit

IM 01B04K03-02E 6th Edition

CONTENTS

1.	INTRODUCTION	1-1
1.1	Inspection.....	1-2
1.2	Documentation Conventions	1-3
1.3	Notice.....	1-3
1.4	About Compatibility with the Conventional Model (Style E)	1-5
2.	GENERAL	2-1
2.1	Standard Specifications.....	2-2
2.1.1	Input Signals	2-2
2.1.2	Output Signals.....	2-3
2.1.3	Power Consumption.....	2-3
2.1.4	Mounting and Dimensions	2-3
2.1.5	Normal Operation Conditions	2-3
2.1.6	mV, Thermocouple, and RTD Accuracy Guaranteed.....	2-4
2.2	Model and Suffix Codes	2-5
2.3	Accessory	2-6
3.	INSTALLATION	3-1
3.1	External Wiring	3-1
4.	FUNCTIONS	4-1
4.1	Operation Principle	4-1
4.1.1	Hardware Block Diagram	4-1
4.2	Input Processing Function	4-3
4.3	Alarm Processing Function.....	4-5
4.3.1	Alarm-Detecting Sections	4-6
4.3.2	Alarm Connection / Output Sections.....	4-7
4.3.3	Example of Setting the Alarm Functions.....	4-10
4.4	Retransmission Output Function (for /VLT and /CUR Options)	4-11
4.5	Communication Function (for /COM Option)	4-12
4.6	Function of Recovery from Power Failure.....	4-13
4.7	Self-Diagnostic Function	4-14
4.8	Alarm/Failure Outputs at Power-on and Power Failure	4-15

5.	SETTING	5-1
5.1	Names of Components	5-3
5.2	Part Names of the Display Setter.....	5-4
5.3	Setting Jumpers	5-6
	5.3.1 Checking Setting Jumpers and their Locations	5-7
	5.3.2 Change of Setting Jumper	5-8
5.4	Settings Done from the Front Panel of the Alarm Unit.....	5-9
	5.4.1 How to Operate the Key Switches	5-9
	5.4.2 Settings Using Key Switches (Example).....	5-10
5.5	Parameter Change Disable Function	5-11
5.6	Various Display Modes	5-12
	5.6.1 Display at Power ON.....	5-12
	5.6.2 LOCK Display.....	5-12
	5.6.3 Display in Display Shutoff Mode	5-12
	5.6.4 Error Display	5-13
	5.6.5 Display of Self-Diagnostic Results	5-13
	5.6.6 Detailed Alarm Status Display	5-14
5.7	Settings Using the JHT200 Handy Terminal	5-16
6.	PARAMETERS	6-1
6.1	Configuration of Parameters.....	6-1
6.2	Display on Front Panel : Development View of Parameters	6-2
6.3	Display on Front Panel : List of Parameters.....	6-6
6.4	JHT200 Handy Terminal : List of Parameters	6-22
7.	MAINTENANCE	7-1
7.1	Test Equipments.....	7-1
7.2	Reference Table of Thermocouple and RTD.....	7-1
7.3	Adjustment and Check	7-1
	7.3.1 Input Adjustment	7-2
	7.3.2 Correction of Input Wiring Resistance	7-4
7.4	Check of Reference Junction Temperature Compensation Action ...	7-6
7.5	Replacement of Fuse	7-7
7.6	Replacement of Capacitor	7-8
7.7	Replacement of Relays	7-8
8.	TROUBLESHOOTING	8-1
8.1	Troubleshooting Flow	8-1
8.2	Actions under Fault Conditions.....	8-2
8.3	Replacement of Parts.....	8-6
	8.3.1 Replacement Procedure	8-6
	8.3.2 Replacement of Power Supply Unit	8-7
	8.3.3 Replacement of Internal Unit	8-7
	8.3.4 Replacement of Display	8-7

Appendix /TB Power Supply Terminal Connections (Option).....	App.-1
Appendix-1 GENERAL	App.-1
Appendix-2 APPLICABLE INSTRUMENTS	App.-1
Appendix-3 NAMES OF COMPONENTS AND POWER TERMINAL SYMBOLS.....	App.-1
Appendix-4 POWER SUPPLY AND GROUND WIRING	App.-2
Model SDAU (Style R) Digital Alarm Unit	CMPL 01B04K03-02E
/TB Power Supply Terminals For Rack-Mounted Instruments (Option)	
.....	CMPL 01B04F02-11E
Revision Information	i

Blank Page

1. INTRODUCTION

This manual describes the functions and operations of the SDAU Digital Alarm Unit.

■ Intended Readers

This manual is intended for personnel in charge of:

- Installation and wiring
- Instrumentation and setup of functions
- Operation and monitoring of the controller
- Maintenance of equipment

■ Related Documents

The following documents all relate to the SDAU Digital Alarm Unit. Read them as necessary. The codes enclosed in parentheses are the document numbers.

- Rack-Mounted Instruments (IM 1B4F2-01E)
Describes mounting and wiring for YS80 rack-mounted instruments.
- Model JHT200 Handy Terminal (IM JF81-02E)
Describes operation of JHT200.
- YEWSERIES 80 Installation Manual (TI 1B4A9-01E)
Describes the installation conditions of YS80 instruments.
- YS80*R Rack-Mounted Instruments Communication Functions (IM 01B04F01-20E)
Describes the communication functions of SDAU.

1.1 Inspection

The SDAU digital alarm unit is shipped only after stringent inspection at the factory. Visually inspect the product upon delivery to make sure it is not damaged in any way.

Store the box and inner packing material of the package in a safe place / they may be needed if there is a problem with the product and it needs to be sent back for repair.

■ Check of Model and Suffix Codes

The model and suffix codes are indicated on the Name plate attached to the front cover of the instrument. Crosscheck this information with the model and suffix codes of Section 2.2 to ensure that the product is as specified in the order.

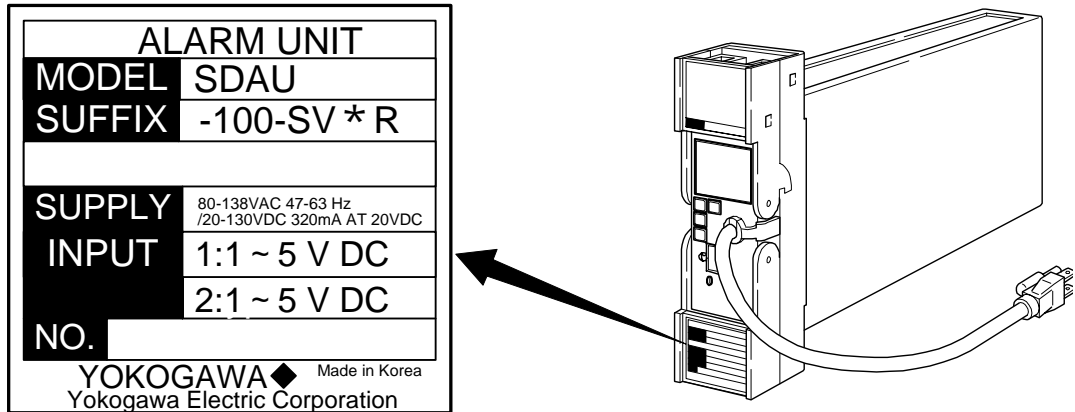

Figure1.1 Name Plate

■ Confirmation of the Package Contents

Check the package contents against the list below. If anything is missing or damaged, immediately contact the sales office from which you purchased the product or your nearest Yokogawa representative.

- SDAU Digital Alarm Unit 1
- Alarm Label (Parts No.: L4040JA) 1 sheet
- Fuse (Parts No.: S9510VK) 1
- Reference Junction Bracket (Parts No.: L4040EN)
(only for SDAU-120-xx*R/NHR or SDAU-270-xx*R/NHR) 1
- User's Manual (This manual)..... 1
- Communication Functions User's Manual (IM01B04F01-20E)
(only for model with the /COM option
(RS-485 communication function)) 1

1.2 Documentation Conventions

This manual uses the following notational conventions.

■ Symbols

The following symbols are used in this manual.



WARNING

Indicates that operating the hardware or software in a particular manner may damage it or result in a system failure.



NOTE

Draws attention to information that is essential for understanding the operation and/or features of the product.

TIP

Gives additional information to complement the present topic and/or describes terms specific to this document.

See Also

Gives reference locations for further information on the topic.

■ Description of Displays

Some of the representations of product displays shown in this manual may be exaggerated, simplified, or partially omitted for reasons of convenience when explaining them.

1.3 Notice

■ This User's Manual

- This manual should be passed on to the end user. Keep at least one extra copy of the manual in a safe place.
- Read this manual carefully to gain a thorough understanding of how to operate this product before you start using it.
- This manual is intended to describe the functions of this product. Yokogawa Electric Corporation (hereinafter simply referred to as Yokogawa) does not guarantee that these functions are suited to the particular purpose of the user.
- Under absolutely no circumstances may the contents of this manual, in part or in whole, be transcribed or copied without permission.
- The contents of this manual are subject to change without prior notice.
- Every effort has been made to ensure accuracy in the preparation of this manual. Should any errors or omissions come to your attention however, please contact your nearest Yokogawa representative or sales office.

■ Protection, Safety, and Prohibition against Unauthorized Modification

- The following safety symbols are used on the product and in this manual.



If this symbol is indicated on the product, the operator should refer to the explanation given in the user's manual in order to avoid personal injury or death to either themselves or other personnel, and/or damage to the instrument. The manual describes that the operator should exercise special care to avoid shock or other dangers that may result in injury or loss of life.



Protective ground terminal:

This symbol indicates that the terminal must be connected to ground prior to operating the equipment.



Function ground terminal:

This symbol indicates that the terminal must be connected to ground prior to operating the equipment.



AC voltage:

This symbol indicates that AC voltage is present.



DC voltage:

This symbol indicates that DC voltage is present.

- In order to protect the product and the system controlled by it against damage and ensure its safe use, make certain that all of the instructions and precautions relating to safety contained in this document are strictly adhered to. Yokogawa does not guarantee safety if products are not handled according to these instructions.
- If protection/safety circuits are to be used for the product or the system controlled by it, they should be externally installed on the product.
- Do not turn off the power of the product during adjustment.
- When you replace the parts or consumables of the product, only use those specified by Yokogawa.
- Do not modify the product.

■ Force Majeure

- Yokogawa does not make any warranties regarding the product except those mentioned in the WARRANTY that is provided separately.
- Yokogawa assumes no liability to any party for any loss or damage, direct or indirect, caused by the use or any unpredictable defect of the product.

1.4 About Compatibility with the Conventional Model (Style E)

- The operation and function differ from the conventional model.
Read this manual carefully to gain a thorough understanding of how to operate this product before you start using it.
- Be sure to confirm the parameters such as alarm set point and setting jumper referring to "6. PARAMETERS" before installing the product in a system or plant. After confirming them, install the product in a system or plant and turn on the power.
- When replacing an internal unit with the old style code (SDAU-1xx-xx*E) with an internal unit with the SDAU-120-xx*R or SDAU-270-UN*R style code, the reference junction contact fitting (for contact with the RJC sensor) must be installed (or replaced). For more information, see Section 2.3, "Accessory."

Blank Page

2. GENERAL

The SDAU Digital Alarm Unit accepts two input signals (freely selectable from 1 to 5 V, mV, thermocouple, and RTD), and six detection results present in alarm-detecting sections are freely AND-connected or OR-connected. These results are then output to alarm relays (two points, or four points if the optional suffix is specified).

Each alarm-detecting section detects high limit and low limit alarms of an input absolute value, input rate-of-change, and two-input deviation. Either a normally energized or de-energized state is selectable for alarm output relays.

The digital display and key switches on the front panel allow input values to be displayed and parameters such as alarm setpoints to be set or changed.

Parameters can also be set or changed by using the JHT200 Handy Terminal^{*1}. The self-diagnostic function also allows failure outputs to be generated.

*1: The BT200 BRAIN Terminal of Yokogawa Electric Corporation can also be connected. Modular jack adapter (part no.: E9786WH) is required to connect the JHT200 Handy Terminal or BT200 to the Digital Alarm Unit.

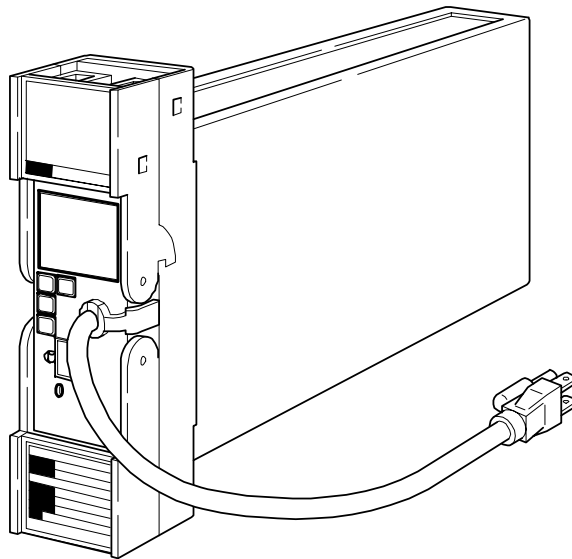

Figure 2.1 Appearance of the SDAU Digital Alarm Unit

2.1 Standard Specifications

2.1.1 Input Signals

Table 2.1 Input Signal Specifications

Specifications	Description	
Input signal types and standards	DC voltage input	1 to 5 V DC -50 to 150 mV DC
	Thermocouple input	Types: K, T, J, E, B, R, S, N, W3, W5 (N, W3, and W5 are for SDAU-270 only.) Standards: JIS '95, IEC, ANSI, BS, and ASTM E988
	RTD input	Three-wire JPt100 (JIS '89), Pt100 (JIS '89, JIS '97), Pt50 (JIS '81) {Pt100 (JIS '89) is for SDAU-270 only.} Measuring current: 0.2 mA DC
Input accuracy	1 to 5 V input	See subsection 2.1.6, "mV, Thermocouple, and RTD Accuracy Guaranteed Ranges."
Number of input points	For SDAU-1x0	1 to 5 V DC: 2 points (not mutually isolated between inputs) Two points of the following (not mutually isolated between inputs) One 1 to 5 V DC and one of mV, thermocouple, or RTD
	For SDAU-270	Two points of universal inputs (not mutually isolated between inputs) (Selectable from mV, thermocouple, and RTD)
Input resistance	DC voltage inputs and thermocouple inputs	1 M Ω (energized), 4 k Ω (de-energized)
External input resistance	mV and thermocouple inputs	500 Ω or less
	RTD inputs	10 Ω /wire or less (input conductor resistance)
Input overload	\pm 4 V DC or less (for mV, thermocouple, or RTD input)	
Burnout time	60 seconds (when a burnout is selected)	

2.1.2 Output Signals

Table 2.2 Output Signal Specifications

Specifications	Description	
Alarm output: Types and number of output points	For options other than /RLY4	Transfer contact: 2
	For /RLY4	NC,NO contact: 4 (NC and NO are switched using a jumper.)
Failure output: Types and number of output points	For options other than /RLY4, /VLT, and /CUR	NC or NO relay contact: 1 Always normal-state energization
	For /RLY4, /VLT, and /CUR	None
Output relay contact capacity and electrical service life	100 V AC: 2 A (resistive load) 220 V AC: 0.5 A (resistive load) 30 V DC: 2 A (resistive load) 125 V DC: 0.5 A (resistive load)	
	Electrical service life: 600,000 times	
Alarm action repeatability	Same as the input accuracy	
Retransmission output: Types and number of output points (Optional)	For /VLT	1 to 5 V DC output: 1
	For /CUR	4 to 20 mA output: 1
Retransmission output accuracy (Optional)	1 to 5 V DC (/VLT)	Accuracy: ±0.1% of span Resistive load: 2 KΩ or more
	4 to 20 mA (/CUR)	Accuracy: ±0.1% of span Resistive load: 750 Ω or less

2.1.3 Power Consumption

Table 2.3 Power Consumption

Current and power consumption	240 mA for 24 V DC 17 VA for 100 V AC 22 VA for 220 V AC
-------------------------------	--

2.1.4 Mounting and Dimensions

Table 2.4 Mounting and Dimensions

Mounting	Mounting: Install in an indoor rack. Signal connection: M4 screw terminal Power supply and grounding connections: 100 V version JIS C 8303 grounded 2-prong attachment plug 200 V version CEE 7VII (International Commission on Rules for the Approval of Electrical Equipment) plug Cable length: 300 mm
External dimensions	180 × 48 × 300 mm (height, width, and depth from the mounting surface)
Weight	Approx. 2 kg (including the rack case)

2.1.5 Normal Operating Conditions

Table 2.5 Normal Operating Conditions

Specifications	Description
Ambient temperature	0 to 50°C
Ambient humidity	5 to 90% R.H. (no condensation)
Supply voltage	Both DC and AC usage 100-V version DC: 20 to 130 V, no polarity 100-V version AC: 80 to 138 V, 47 to 63 Hz 220-V version DC: 120 to 340 V, no polarity 220-V version AC: 138 to 264 V, 47 to 63 Hz

2.1.6 mV, Thermocouple, and RTD Accuracy Guaranteed Ranges

- Accuracy ratings are specified under the standard test conditions (23 ±2°C, 50% ±10% RH).
- Effect of ambient temperature: accuracy × 2 per 10°C

Table 2.6 mV, Thermocouple, and RTD Accuracy Guaranteed Range

Input signal	Input range	Accuracy
DCV input	1 to 5V DC	± 0.1%
	-50.0 to 150.0mV DC	± 20μV

Termocouple	Input range (°C)	Accuracy (°C) (*1)	
Type K (ITS-90, JIS '95)	-270.0 to 1372.0	-270.0 to 0.0	± {0.5+A (*2)} (°C)
		0.0 to 1300.0	± 0.5 (°C)
		1300.0 to 1372.0	± 1.0 (°C)
Type T (ITS-90, JIS '95)	-270.0 to 400.0	-270.0 to 0.0	± {0.3+A (*2)} (°C)
		0.0 to 400.0	± 0.3 (°C)
Type J (ITS-90, JIS '95)	-210.0 to 1200.0	-210.0 to 0.0	± {0.3+A (*2)} (°C)
		0.0 to 1100.0	± 0.3 (°C)
		1100.0 to 1200.0	± 1.0 (°C)
Type E (ITS-90, JIS '95)	-270.0 to 1000.0	-270.0 to 0.0	± {0.3+A (*2)} (°C)
		0.0 to 900.0	± 0.3 (°C)
		900.0 to 1000.0	± 1.0 (°C)
Type B (ITS-90, JIS '95)	100.0 to 1820.0	100.0 to 600.0	± {3.0+A (*3)} (°C)
		600.0 to 1820.0	± 3.0 (°C)
Type R (ITS-90, JIS '95)	-50.0 to 1768.0	-50.0 to 0.0	± 4.0 (°C)
		0.0 to 400.0	± 2.0 (°C)
		400.0 to 1768.0	± 1.0 (°C)
Type S (ITS-90, JIS '95)	-50.0 to 1768.0	-50.0 to 0.0	± 4.0 (°C)
		0.0 to 400.0	± 2.0 (°C)
		400.0 to 1768.0	± 1.0 (°C)
Type N (ITS-90, JIS '95)	-270.0 to 1300.0	-270.0 to 0.0	± {1.0+A (*2)} (°C)
		0.0 to 1300.0	± 1.0 (°C)
Type W3 (ASTM E988) (*4)	0 to 2315	0 to 2315	± 2.0 (°C)
Type W5 (ASTM E988) (*5)	0 to 2315	0 to 2315	± 2.0 (°C)

RTD	Input range	Accuracy
JPt100 (JIS '89)	-200.0 to 510.0	± 0.25 (°C)
Pt50 (JIS '81)	-200.0 to 649.0	
Pt100 (ITS-90, JIS '97)	-200.0 to 850.0	
Pt100 (IPTS-68, JIS '89)	-200.0 to 660.0	

(*1) For thermocouple inputs, add the reference junction compensation error (see below) to the accuracy above.

Add the following (1) or (2), whichever is the larger:

(1) All types except types R, S, W3 and W5: 0.5°C

Types R, S, W3 and W5: 1°C

(2) Multiply the value in (1) by K,

where K=(Thermocouple output change/°C near normal temperature)

÷ (Thermocouple output change /°C near input temperature.)

(*2) For measured temperatures below 0 °C, add the following A to the accuracy above.

- Measured temperature : -200 °C to below 0 °C

A = 0.0025 x | measured temperature |

- Measured temperature : below -200 °C

A = 0.1 x | measured temperature |

(*3) For measured temperatures below 600 °C, add the following B to the accuracy above.

- Measured temperature : 300 °C to below 600 °C

B = 0.02 x | measured temperature - 600 |

- Measured temperature : below 300 °C

B = 0.1 x | measured temperature - 300 | + 6

(*4) ASTM E988 Standard: W97Re3-W75Re25 (tungsten97% rhenium3%-tungsten75% rhenium25%)

(*5) ASTM E988 Standard: W95Re5-W74Re26 (tungsten95% rhenium5%-tungsten74% rhenium26%)

2.2 Model and Suffix Codes

The following table shows the SDAU model and suffix codes.

Table 2.7 Model and Suffix Codes

Model	Suffix Codes	Auxiliary Codes	Style	Optional Suffix Codes	Description
SDAU					Digital Alarm Unit
Input Signal 2	-1				Input signal 2: 1 to 5 V
	-2				Input signal 2: Universal (Note 3)
Input Signal 1	0				1 to 5 V
	1				mV
	2				TC (Thermocouple)
	3				RTD
	7				Universal (Note 3)
Always 0	0				Always 0
Available Combination Standard Specifications: SDAU-100, SDAU-110 SDAU-120, SDAU-130 SDAU-270 Auxiliary Codes: SDAU-100: -SV SDAU-110: -MV SDAU-120: from -TK to -TS SDAU-130: from -PA to -PD SDAU-270: -UN		-SV			Two points of 1 to 5 V inputs
		-MV			mV input
		-TK			Type K (ITS-90,JIS'95)
		-TT			Type T (ITS-90,JIS'95)
		-TJ			Type J (ITS-90,JIS'95)
		-TE			Type E (ITS-90,JIS'95)
		-TB			Type B (ITS-90,JIS'95)
		-TR			Type R (ITS-90,JIS'95)
		-TS			Type S (ITS-90,JIS'95)
		-PA			JPt 100 (JIS'89)
		-PB			Pt50 (JIS '81)
		-PD			Pt100 (ITS-90, JIS'97)
		-UN			Universal (Note 3)
Style Code			*R		Style R
Common Options				/A2ER	220 V version power supply plug
				/NHR	Without case
				/TB	With power supply terminal
				/VLT	With 1 to 5 V output (Note 1)
				/CUR	With 4 to 20 mA output (Note 1)
				/RLY4	Four points of alarm outputs (Note 1)
				/COM	With RS-485 communication function
			/BU	Burnout upscale (Note 2)	
			/BD	Burnout downscale (Note 2)	

Note 1: /VLT, and /CUR options can be combined with only -UN auxiliary code.

/RLY4 option can be combined with only -SV or -UN auxiliary codes.

/VLT, /CUR and RLY4 options can not be combined with each other.

Note 2: For two points of 1 to 5 V inputs (-SV), burnout upscale or burnout downscale is not selectable.

Note 3: For universal inputs, 1 to 5 V is not selectable.

2.3 Accessory

Fuse 1A : 1

Reference junction bracket : 1

(For SDAU-120-xx*R/NHR or SDAU-270-xx*R/NHR)

Alarm label : 1

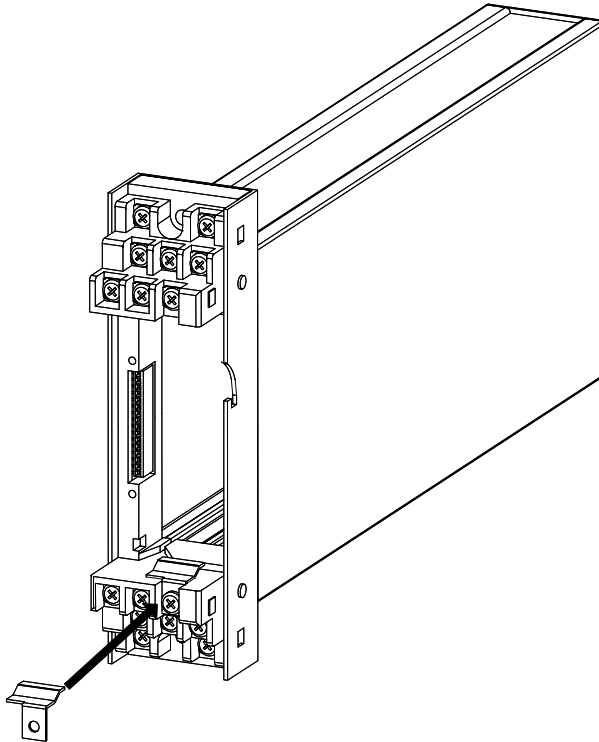

Figure 2.2 Location of the Reference Junction Bracket



NOTE

- The fuse (S9510VK) is the dedicated fuse, Do not use it for other products.
- Notice when replacing the internal unit of a conventional model:

When replacing the internal unit of a conventional model (SDAU-1xx-xx*E) with that of SDAU-120-xx*R or SDAU-270-UN*R, a reference junction bracket (for connection to the RJC sensor) needs to be installed (replaced).

For SDAU-120-xx*E

Replace a reference junction bracket (for connection to the RJC sensor).

For models other than SDAU-120-xx*E

Install a reference junction bracket (for connection to the RJC sensor).

3. INSTALLATION

For details of the installation procedure and wiring precautions, refer to the technical information “YEW SERIES 80 Installation Manual” (TI 1B4A9-01E) or the instruction manual “Installation of Rack-Mounted Instruments” (IM 1B4F2-01E).

3.1 External Wiring

- (a) All cable ends must be furnished with crimp-on type solderless lugs (for 4mm screws).
- (b) Draw out the internal unit from the rack case.
- (c) Connect the cable to the correct terminals referring to Figure 3.1.
- (d) Return the internal unit into the rack case after completing the wiring.
- (e) Always return the terminal block cover to its original position after completing the wiring.



NOTE

The terminal block cover cannot be returned to its original position if the internal unit is not installed correctly inside in the rack case. Securely return the terminal block cover because it also functions as lock for the internal unit.

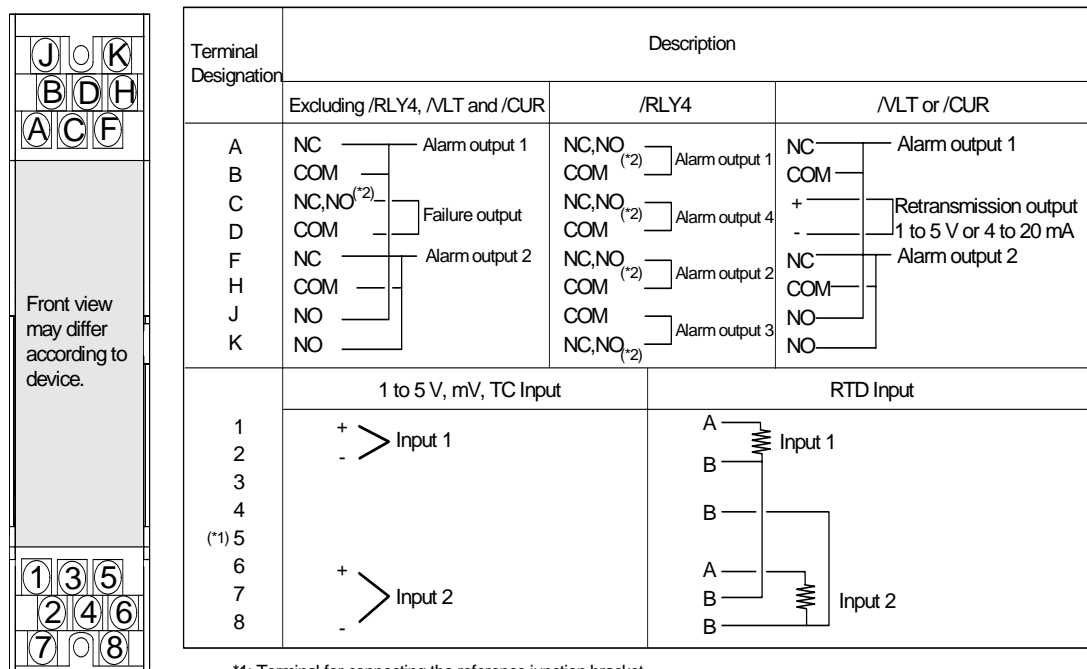

*1: Terminal for connecting the reference junction bracket.
 *2: Switch NC/NO using jumper.
 NC: Relay normally closed contact (closed when relay de-energized).
 NO: Relay normally open contact (open when relay de-energized).

Figure 3.1 Terminal Layout and Terminal Wiring

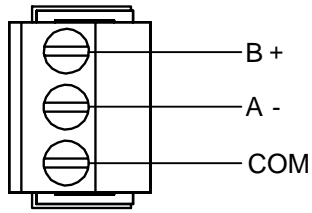

Figure 3.2 RS485 Communication Terminal Layout (/COM option)

■ Applicable Cables

(1) Signal circuit wiring

- Cross-sectional area of the cable conductor: 0.5 to 0.75 mm²
- Examples of applicable cables: Single core PVC insulated flexible cable (VSF) stranded wires (JIS C 3306); heat-resistant vinyl-insulated cable (UL style 1007)

(2) Alarm circuit wiring

- Cross-sectional area of the cable conductor: 0.5 to 1.25 mm²
- Examples of applicable cables: 600 V PVC insulated cable (IV) stranded wires (JIS C 3307); PVC insulated cable for electric appliances (KIV) stranded wires (JIS C 3316); heat-resistant vinyl-insulated cable (UL style 1007)

(3) Power supply wiring

- Cross-sectional area of the cable conductor: 1.25 to 2.00 mm²
- Examples of applicable cables: 600 V PVC insulated cable (IV) stranded wires (JIS C 3307)

4. FUNCTIONS

4.1 Operation Principle

Input signals are converted into digital data by an A/D converter circuit. This digital data is signal processed (such as linearization or square root extraction) by a microprocessor and then computed for alarm detection. Alarm relays are energized or de-energized according to the alarm computation outputs.

For retransmission output, an input signal is pulse-width modulated after being signal processed. It is then converted into 1 to 5 V DC or 4 to 20 mA DC signals via a photo-isolation circuit.

4.1.1 Hardware Block Diagram

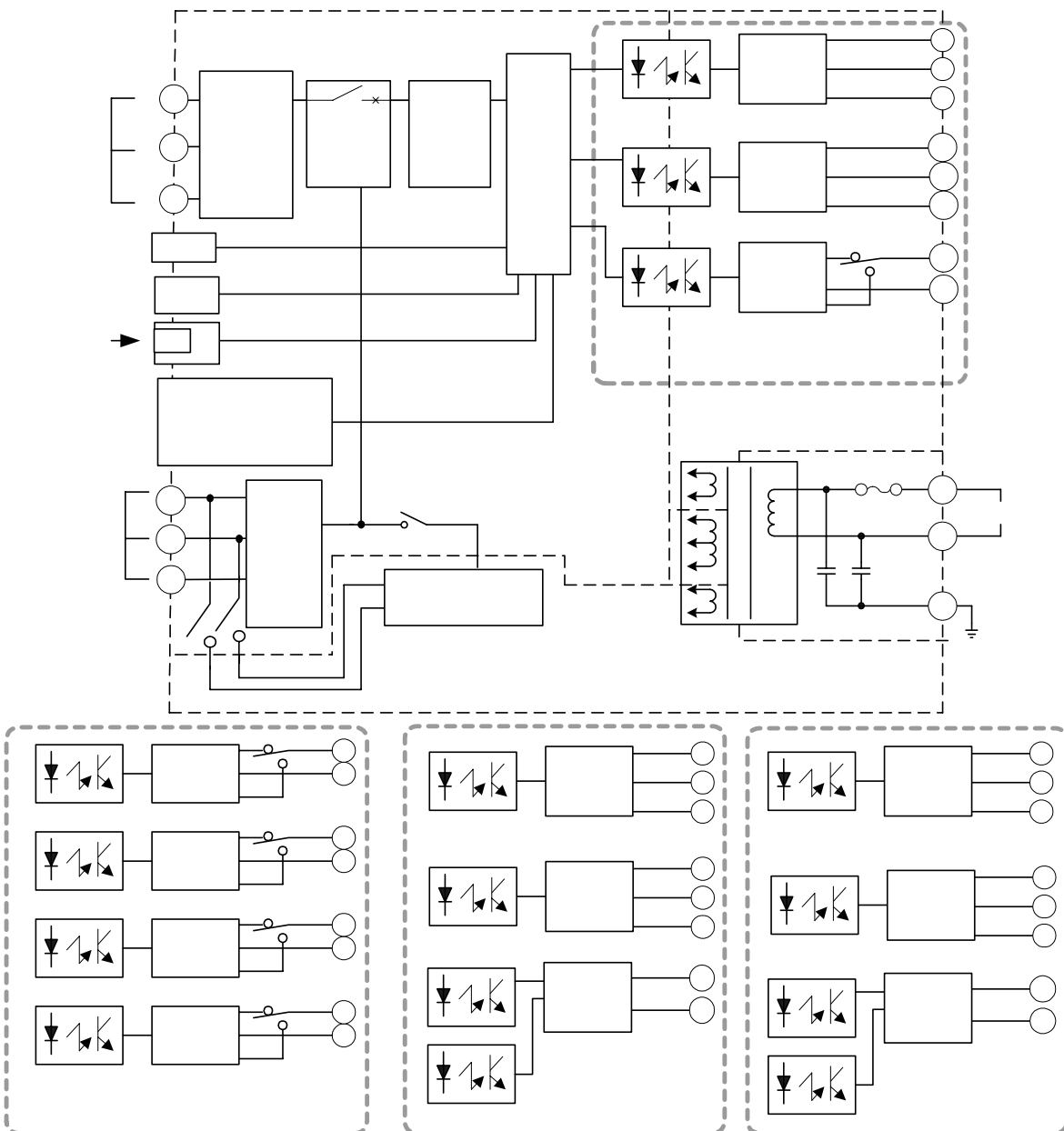

Figure 4.1 Hardware Block Diagram

Internal Function Block Diagram

The following shows the internal function block diagram. For more information, see the Description of Each Function section.

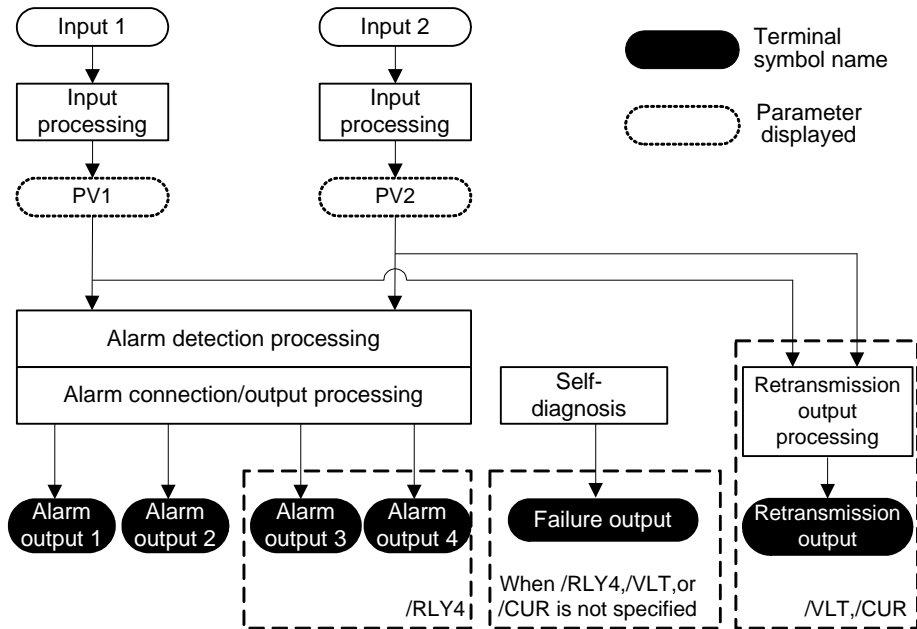

Figure 4.2 Internal Function Block Diagram

4.2 Input Processing Function

Two input points are provided. The following processing is done with respect to each input (see Figure 4.3). Encircled symbols are parameter symbols appearing on the display setter. "n" takes value 1 or 2.

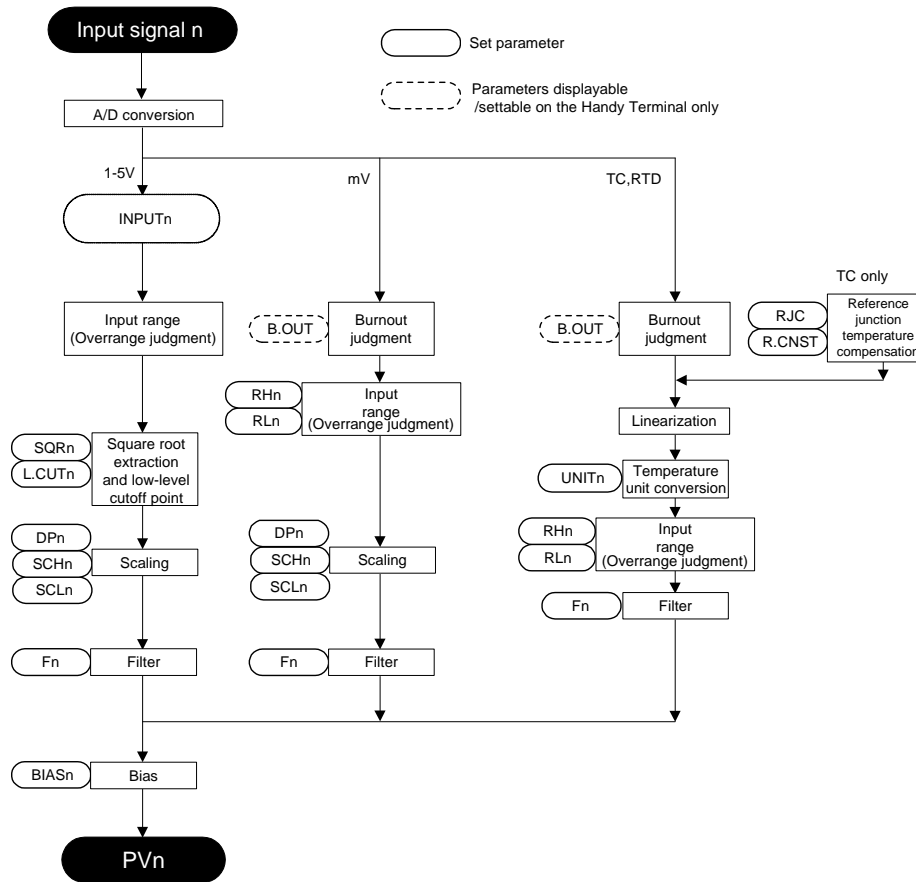

Figure 4.3 Input Processing Function Block Diagram

● Description of Each Function:

- A/D conversion: Performs A/D conversion of input signals.
- Burnout (B.OUT): If an input signal is mV, thermocouple, or RTD input, the action to be taken in case of burnout can be set. (This can be specified according to an option code. Settings can be changed via the JHT200 Handy Terminal after delivery.)
- Temperature unit conversion (UNITn): Allows temperature units (°C, K or °F) to be set if an input signal is thermocouple or RTD input.

- Input range (RHn, RLn): An input range should be set if an input signal is mV or temperature input. If an input value is -6.25% or less, or greater than 106.25% of the input range, an input overrange occurs. For actions to be taken in the event of an input overrange, see Section 8.2, "Actions under Fault Conditions."
- Square root extraction (SQRn, L.CUTn): If an input signal is 1 to 5 V DC, the availability of square root extraction and a low-level cutoff point can be specified. Specification of a low-level cutoff point is enabled only when square root extraction is available. For inputs below the low-level cutoff point, no square root is extracted. (Linear characteristics apply for any inputs below the low-level cutoff point.)
- Filter (Fn): This is a first-order lag filter. The time constant can be set in the range of 0.0 to 200.0 seconds. Note that for the actual time constant, a hardware filter time constant of approx. 0.1 second will be added to the noted setting.
- Scaling (DPn, SCHn, SCLn): If an input signal is mV or 1 to 5 V DC, scaling can be applied to a range specified by the input range (RHn, RLn). A value converted by scaling (a value obtained by adding bias to this value if bias is used) becomes PVn. The initial value of scaling is 0.0 to 100.0 (DPn=1, SCHn=100.0, SCLn=0.0).

<How to Set Input Range and Scaling>

The following is the example when input range of 10.0 to 80.0 mV is scaled to 1000 to 20000.

- (1) Set the input range at the parameters RL1 and RH1.
(Example: RL1=10.0, RH1=80.0)
- (2) Set the input decimal point position matched to the unit system actually in use at DP1.
(Example: DP1=0)
- (3) Set the scale range at the parameters SCH1 and SCL1.
(Example: SCL1=20000, SCH1=1000)

(Example)

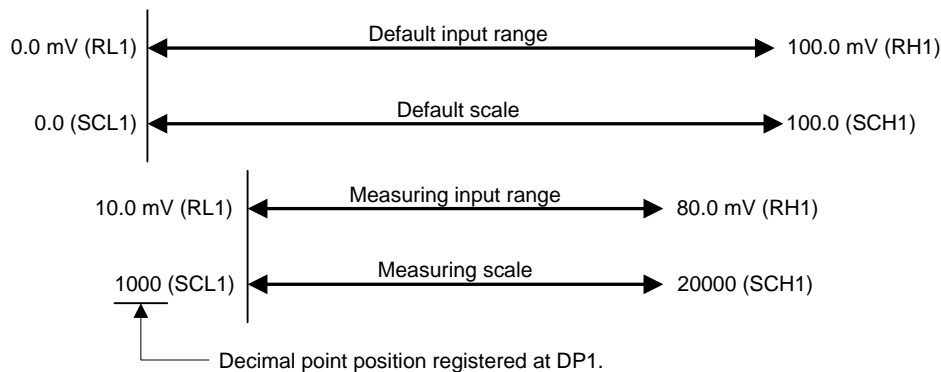

Figure 4.4 Scaling

Note: Reverse scaling (SCH1 < SCL1) is also possible. The alarm unit will not operate normally when SCH1 is set to equal SCL1. Change the setting.

- Bias (BIASn):
A bias value can be added to scaling values.
This allows error to be compensated when there is an error between the input value and the indicated value.
Bias can be set within the range $\pm 10\% [(SCH1 - SCL1) \times 0.1]$ of the scaling width.
- PVn:
The value obtained by adding bias to the scaling value.

4.3 Alarm Processing Function

As shown in Figure 4.5, the SDAU's alarm function consists of the alarm-detecting sections and alarm connection/output sections, each of which functions independent of the others.

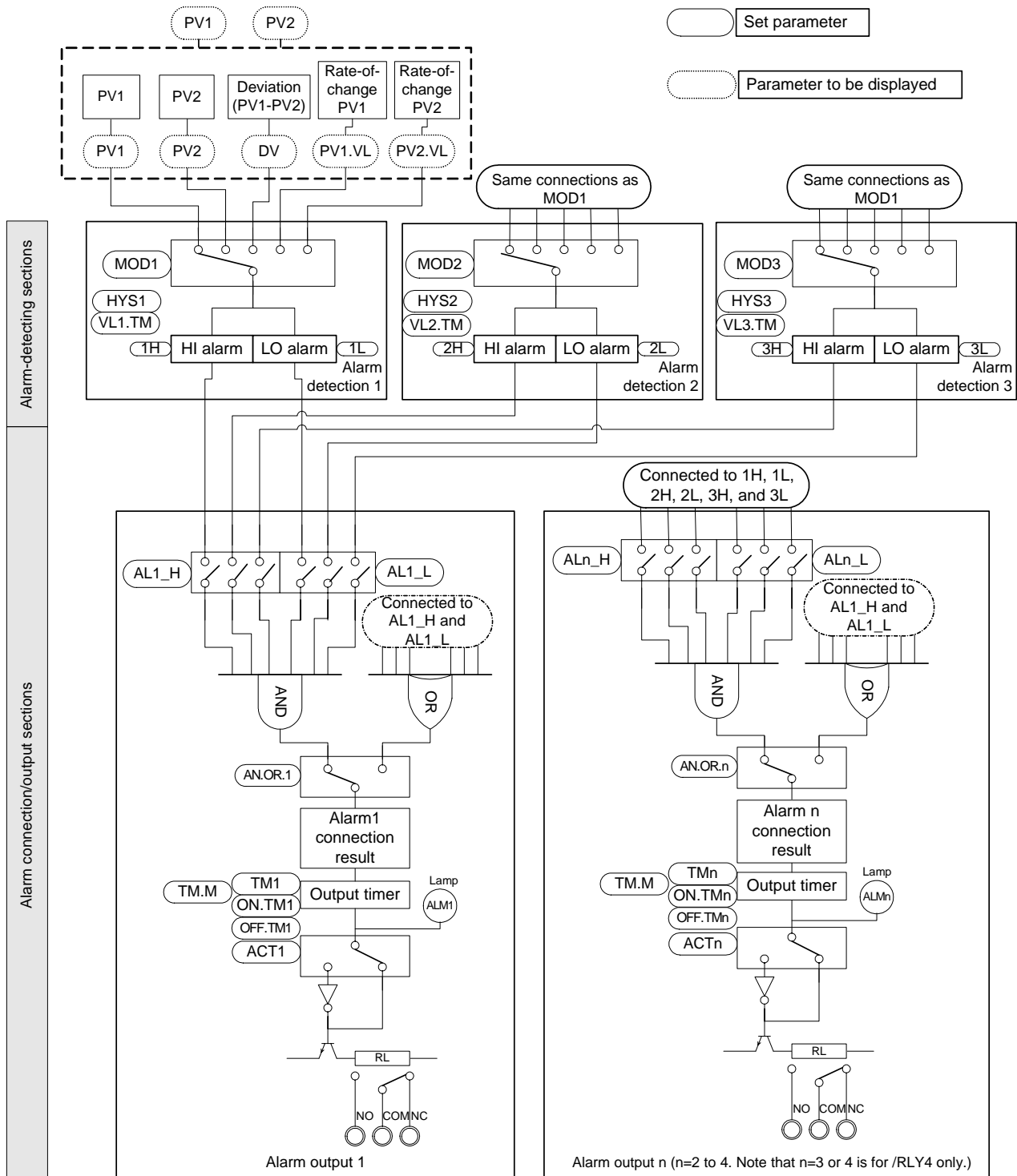

Figure 4.5 Alarm Processing Function Block Diagram

4.3.1 Alarm-Detecting Sections

There are three alarm-detecting sections, which set each of the following items (see Figure 4.5). Those in parentheses show parameter symbols to be displayed on the display setter. "n" takes value 1, 2, or 3.

- Input mode (MODn): Selects a target input at alarm detection-n from among input-1 absolute alarm, input-2 absolute alarm, deviation alarm (input 1 - input 2), input-1 rate-of-change alarm, and input-2 rate-of-change alarm.

If the same PVn rate-of-change alarm is set to the multiple MOD, the rate-of-change of MODn having smaller n value is displayed in PVn.VL parameter.

For example, MOD1=MOD2=MOD3=4:Input 2 rate-of-change (PV2.VL), and VL1.TM=10, VL2.TM=5, VL3.TM=3, PV2.VL displays PV2 rate-of-change for 10 seconds.

- Hysteresis (HYSn): Sets hysteresis at alarm detection-n in engineering units (range: 0 to 32000). (This is not applicable to rate-of-change alarms.)
- Rate-of-change alarm sampling time (VLn.TM): Available when the input mode is set to rate-of-change alarm. A rate-of-change is obtained as follows:

Example: When MOD1 = PV1 rate-of-change alarm and VL1.TM = 10 sec. are set,
Rate-of-change = current value (present PV1 value) - previous value (PV1 value 10 sec. before)

- High-limit alarm setpoint (nH): Sets the high-limit setpoint at alarm detection-n in engineering units (range: -19999 to 32000). High-limit alarm cannot be used as low-limit alarm.
- Low-limit alarm setpoint (nL): Sets the low-limit setpoint at alarm detection-n in engineering units (range: -19999 to 32000). Low-limit alarm cannot be used as high-limit alarm.
- Alarm detection repeatability: Same as input conversion accuracy

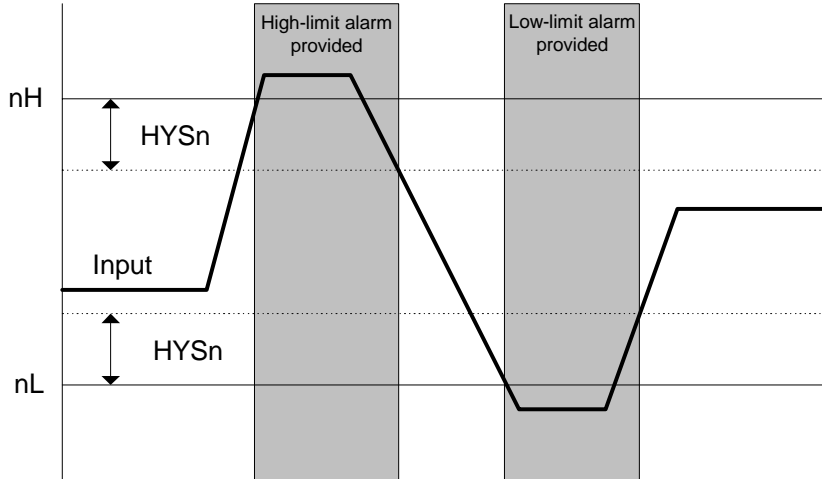

Figure 4.6 Alarm Action When Hysteresis is Set

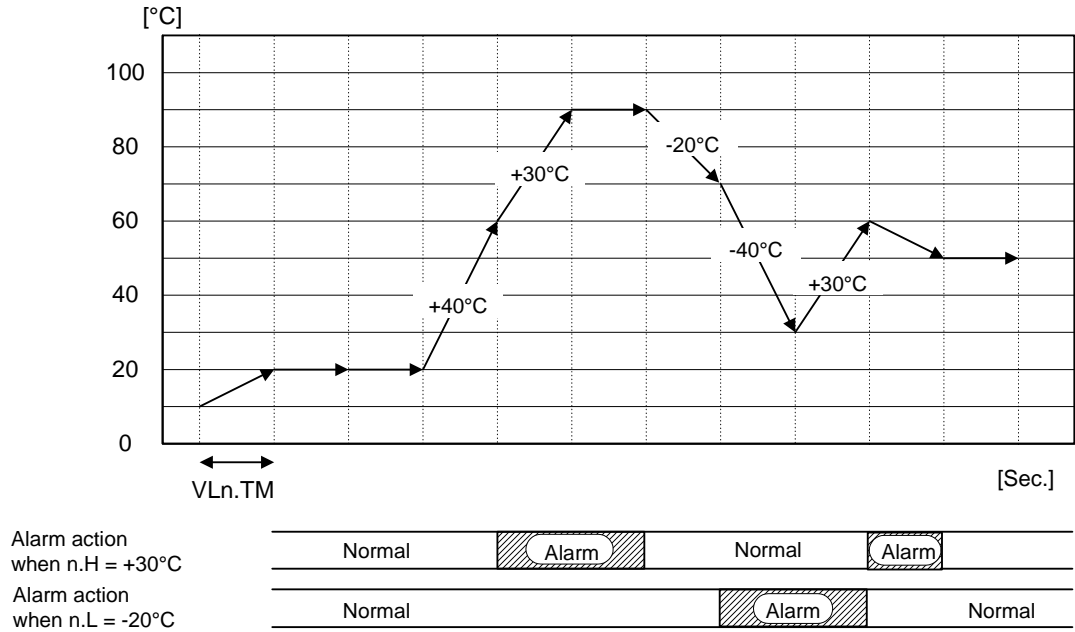

Figure 4.7 Action to be Taken When Input is Rate-of-change Alarm

4.3.2 Alarm Connection/Output Sections

There are two alarm connection/output sections (four for the /RLY4 option), which set each of the following items (see Figure 4.5).

Those in parentheses show parameter symbols to be displayed in the display setter. "n" takes value 1 or 2 (up to 4 for the option /RLY4).

- Alarm output connection (ALn_H, ALn_L): ALn_H specifies whether to connect the high-limit alarm detection results of MOD1 to MOD3. ALn_L specifies whether to connect the low-limit alarm detection results of MOD1 to MOD3.
- Alarm AND/OR specification (AN.OR.n): Specifies if the results of alarm output connections are AND-connected or OR-connected.
- Alarm timer mode (TM.M): Selects the alarm timer mode. This is common to alarm outputs 1 and 2 (or alarm outputs 1 to 4 for the /RLY4 option).
 0: Alarm output timer (timer causing alarm output to delay: equivalent to SDAU*E)
 1: ON/OFF delay timer (alarm dead time)

- Alarm output timer (TMn): Sets the alarm output delay for alarm n. The alarm unit outputs an alarm when the time period set in TMn has elapsed after the connection of alarm n resulted in an alarm status. Time can be specified in the range of 0 to 600 seconds (in 1 sec. intervals). However, a time lag of approx. 0.2 second will be added to this setting as dead time to prevent erroneous alarm action.

Figure 4.8 shows an example of the alarm actions taken by ALM1 when the alarm output timer is set so that alarms to be output to ALM1 are delayed by 15 seconds if an alarm is detected for either the 90.0 (hysteresis: 10.0) high limit alarm setpoint of PV1 or the 95.0 (hysteresis: 20.0) high limit alarm setpoint of PV2.

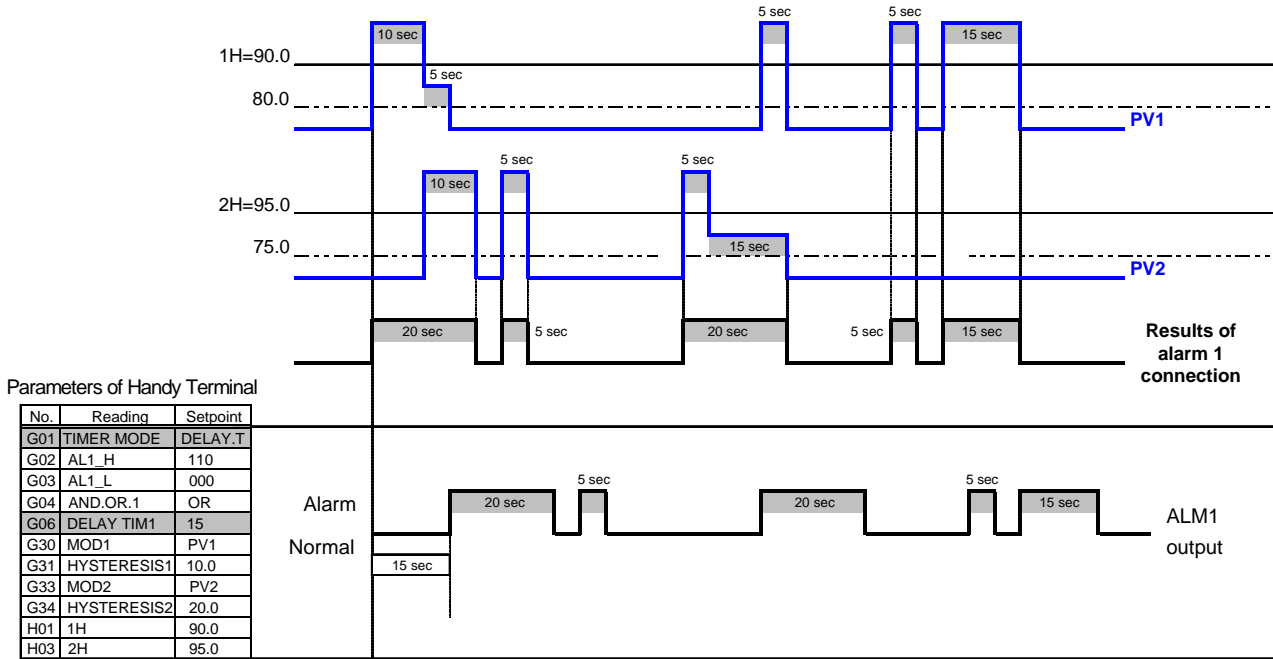

Figure 4.8 Alarm Output Actions to be Taken When Alarm Output Timer is Set

Moreover, if a timer setpoint is changed, alarm status becomes identical with the alarm status of that time, causing the timer function to work from that time on. The alarm output resolution is as shown in the following table according to the setpoint of the alarm output timer.

TMn setpoint (sec.)	Alarm output resolution (sec.)
0 to 39	0.15
40 to 79	0.3
80 to 159	0.6
160 to 319	1.2
320 to 600	2.4

For example, if an alarm status occurs for one second with the alarm output timer set at 600 sec., an alarm is output for 2.4 seconds, between 597.6 to 602.4 seconds later.

ALM1 and ALM2 can be HOT started, while ALM3 and ALM4 are always COLD started. (For HOT/COLD starts, see Section 4.6, "Function of Recovery from Power Failure.")

- Alarm-n ON delay timer (ON.TMn): Sets dead time after which the alarm turns ON. If an input value is within an alarm range for a time set by ON.TMn, an alarm status occurs. If the input returns to the normal range before the time set by ON.TMn elapses, no alarm turns ON.
- Alarm-n OFF delay timer (OF.TMn): Sets dead time after which the alarm turns OFF. If an input value is within a normal range for a time set by OF.TMn, a normal status is brought about. If the input returns to an alarm range before the time set by OF.TMn elapses, the alarm does not turn OFF.

Figure 4.9 shows an example of the alarm actions taken by ALM1 when the alarm n OFF delay timer is set so that the dead time of alarms to be output to ALM1 is 10 seconds and the dead time before these alarms are canceled is 15 seconds if an alarm is detected for either the 90.0 (hysteresis: 10.0) high limit alarm setpoint of PV1 or the 95.0 (hysteresis: 20.0) high limit alarm setpoint of PV2.

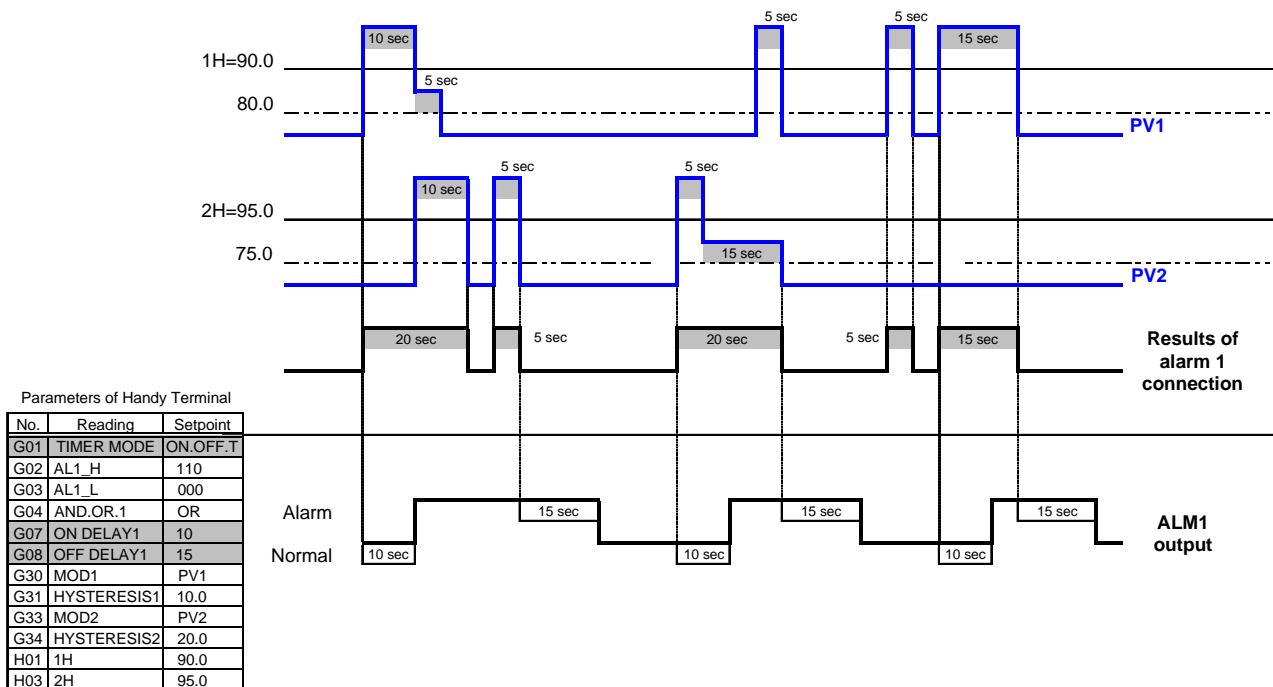

Figure 4.9 Alarm Actions to be Taken When Alarm-n ON/OFF Delay Timers are Set

- Direction of relay action (ACTn): Specifies energized/de-energized status of a relay in a condition where no alarm has occurred.
 - Energized at normal operation (ACTn=1)
A relay is energized when the alarm n detection result is in a normal state.
 - De-energized at normal operation (ACTn=0)
A relay is energized when the alarm n detection result is in an alarm state.
- RLYn TEST: Relay action test (exclusive to the JHT200 Handy Terminal)
This is the relay action test function. It allows a relay to turn ON/OFF regardless of the current alarm detection results. (Note: Make sure that your process is not affected by the relay action test before using this function.)

One set of transfer contacts are provided for each output section. An alarm state can be checked with the ALM lamp on the front panel of the alarm unit (which lights up if an alarm occurs) and by checking the ALMn parameter displayed on the display setter.

4.3.3 Example of Setting the Alarm Functions

Example of Setting 1 Condition A)

ALM1: ALM1 alarm is output if all of the following are generated: the high high-limit alarm of input 1 (1H = 80), the high-limit alarm of input 1 (3H = 70), and the high-limit alarm of input 2 (2H = 50).

ALM2: ALM2 alarm is output if either the high-limit alarm (2H = 50) or low-limit alarm (2L = 40) of input 2 is generated.

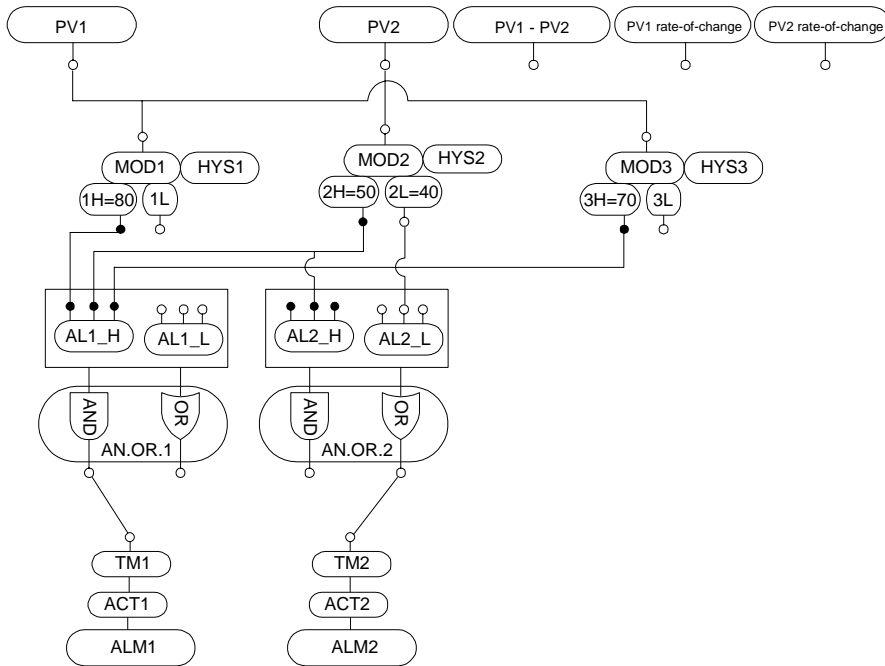

Figure 4.10 Alarm Connections for Condition A

Parameters of Handy Terminal

No.	Reading	Setpoint
G02	AL1_H	111
G03	AL1_L	000
G04	AND.OR.1	AND
G09	AL2_H	010
G10	AL2_L	010
G11	AND.OR.2	OR
G30	MOD1	PV1
G33	MOD2	PV2
G36	MOD3	PV1
H01	1H	80
H03	2H	50
H04	2L	40
H05	3H	70

A19	ALM1	OFF
A20	ALM2	ON

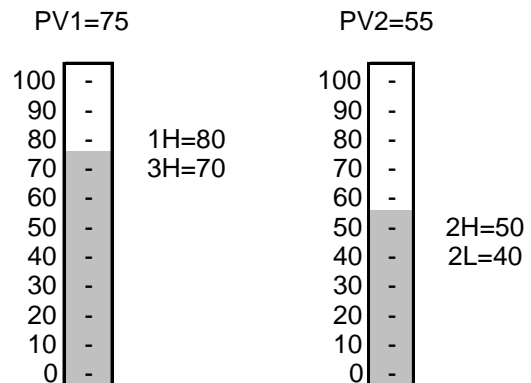

Figure 4.11 Details of Parameter Settings

The parameter settings for condition A are as shown in the table above. When input 1 and input 2 are in the condition as shown in the figure above, the 2H and 3H parameters enter the alarm state and only ALM2 outputs an alarm. (ALM1 outputs no alarm because 1H has not been in the alarm state.)

4.4 Retransmission Output Function (for /VLT and /CUR Options)

The SDAU digital alarm unit with the /VLT or /CUR option can output an input signal as retransmission output in order to use it in a recorder, etc.

The retransmission output function is set using the following parameters.

For more information on each parameter, see Chapter 6, "PARAMETERS."

RET: Selects the retransmission output type (selectable from None, PV1, PV2, and PV1 - PV2)

RTH: Maximum value of retransmission output scale

RTL: Minimum value of retransmission output scale

Retransmission Output Accuracy Guaranteed Range:

	mV input	Thermocouple input	RTD input
Span (RTH-RTL)	10 to 100 mV DC	10 to 63 mV (converted based on thermo electromotive force)	50 to 500°C
Zero elevation (RTL)	Three times the span or within ±50 mV, whichever is smaller	Three times the span or within ±25 mV, whichever is smaller	Five times or less the span

Note1: The retransmission output accuracy guaranteed range is within the noted accuracy range and within 0.0 to 100.0% of the span (RTH - RTL).

4.5 Communication Function (for /COM Option)

The SDAU alarm unit can communicate with a device with an RS-485 communication interface, allowing input values to be read out and/or parameters to be read out or written in.

For more information, see YS80*R Rack-Mounted Instruments Communication Functions User's Manual (IM 01B04F01-20E).

- Communication Interface : 1 channel
- Standards : EIA RS-485
- Communication System : 2-wire, half-duplex
- Baud Rate : 1200, 2400, 4800 and 9600 bps
- Communication Protocol : MODBUS, PC-Link, and Ladder
- Maximum Units Connectable : 31 units
- Maximum Communication Distance : 1200 m
- Communication Cable : Twist pair cable with shield (Wire size: AWG24 or equivalent.)

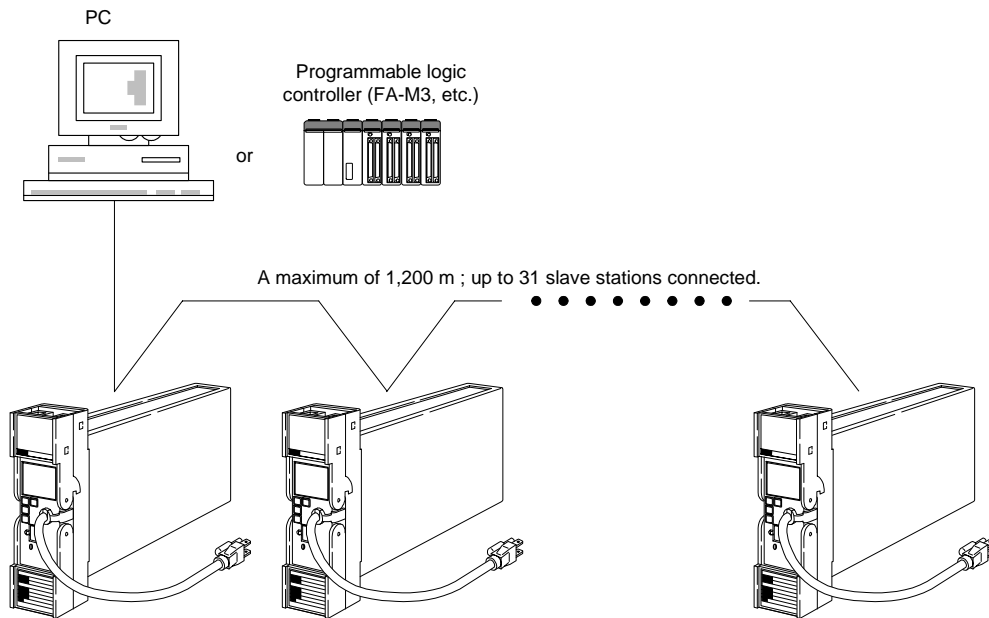

Figure 4.12 Connection with a PC



NOTE

RS-485 communication is not available when the Handy Terminal is connected to the Hand-held terminal connector on the front panel.

When using the Handy Terminal, connect the Handy Terminal after removing the RS-485 connector so that the Handy Terminal connector can be easily disconnected.

Writing via RS-485 communication is not possible if the Parameter Write Protect jumper (W.P.) is set to ON or the Communication Write Protect Setting parameter (COMMU) is set to "1: Protect".

4.6 Function of Recovery from Power Failure

The SDAU alarm unit's recovery from power failure function operates as described below, depending on the setting of the HOT start/COLD start parameter.

HOT start: Continues operation from the alarm status just before a power failure.

Note1: When the alarm timer mode is set to alarm output timer, ALM3 and ALM4 cannot be HOT started.

Note2: HOT starts also cannot be made for rate-of-change alarms. For these alarms, the SDAU judges if an alarm has occurred at the instant when the change time of a rate-of-change alarm has elapsed, by regarding the value at recovery from power failure as the previous value.

COLD start: Starts operation by assuming that power-on input has been continued (provided that hysteresis has not been activated).

The following shows differences in alarm actions between HOT and COLD setpoints.

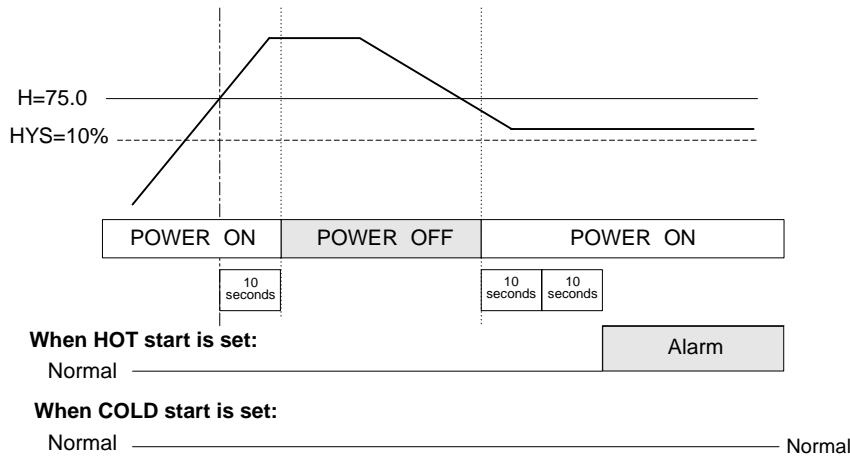

Figure 4.13 Alarm Action for HOT and COLD Starts

Parameter Setting Conditions for the Conditions in the Figure Above

Parameter Symbol	Setpoint
H (alarm setpoint nH)	75.0%
HYS (hysteresis)	10.0%
TM (alarm output timer)	30 seconds

Note : Even when the HOT start parameter is set, if a power failure occurs during any of the following procedures, a HOT start is not possible.

- During input adjustment
- While a parameter is being changed (with a key switch, JHT200 Handy Terminal, or through RS-485 communication)
- During initial setting at power ON

4.7 Self-Diagnostic Function

The SDAU alarm unit has a self-diagnostic function capable of detecting a failure or error in the unit itself.

If an error/failure is detected, notification is made by the following means: an error indication appears on the lower half of the digital display, a parameter is displayed on the upper half of it, a lamp on the front panel of the alarm unit is lit, the failure output contact is de-energized (when /RLY4, /CUR, or /VLT is not specified), and/or an alarm output contact is activated.

For details about the lamps on the front panel of an alarm unit with the /RLY4 option, see Section 5.2, "Part Names of the Display Setter."

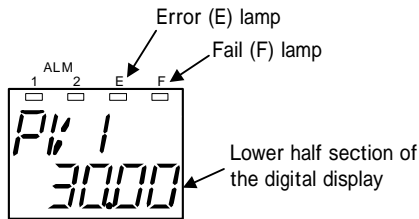

The following describes actions to be taken in the event of error. (For more information, see Section 8.2, "Actions under Fault Conditions.")

- Lighting of F lamp: CPU failure, A/D conversion failure, EEPROM failure, or RJC error
(When the /RLY4 option is specified, this lamp is an indicator for ALM4.)
- Lighting of E lamp: Input signal overrange (Note)
(This lamp lights up if the input is more than 106.25% or less than -6.25% of the input range high limit (RH1) or the input range low limit (RL1).)

Input burnout (Note)

HOT start is disabled (see Section 4.6, "Function of Recovery from Power Failure").
(When the /RLY4 option is specified, this lamp is an indicator for ALM3.)

Note: For input signal overrange or input burnout, the E lamp lights up and a failure output is sent out when the target input signal is connected to an alarm output section.

- Failure output: (only when /CUR, /VLT, or /RLY4 option is not specified)

A failure contact output is provided if the F lamp comes on or the power supply fails. Using the point-of-error failure output action parameter (front display parameter: FAIL.M; Handy Terminal parameter: F40:FAIL MODE), define the action of the failure contact to be taken when the E lamp comes on.

ON (0) = Provides a failure contact output when the E lamp comes on.

OFF (1) = Provides no failure contact output when the E lamp comes on.

(This parameter defaults to ON (0), as with SDAU*E.)

4.8 Alarm/Failure Outputs at Power-on and Power Failure

The alarm and failure outputs function as explained below when the power is turned on or if the power fails.

The following example explains a case where the action is defined as RLYn ACTION=NRM ENERGIZED (normal-state energization) and no alarms or failures have occurred.

When the power is turned on:

- (1) The alarm output starts alarm action in approximately 2 to 3 seconds after power-on.
- (2) The failure output is energized (normal state) in approximately 75 milliseconds after the start of alarm action.

If the power fails:

- (1) The failure output is de-energized (failure state) immediately after the power is cut off.
- (2) The alarm output is also de-energized in approximately 40 milliseconds after the failure output is de-energized.
- (3) The E lamp remains lit for approximately 40 milliseconds after the failure output is de-energized.

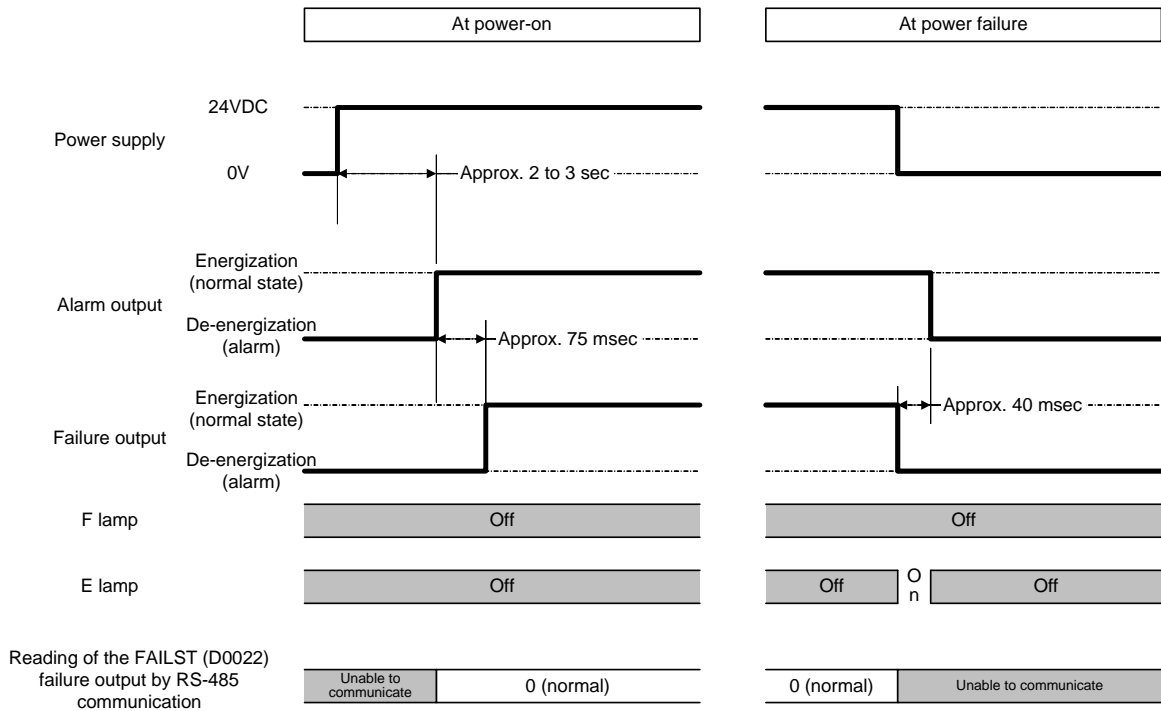

Figure 4.14 Alarm/Failure Outputs at Power-on and Power Failure

Blank Page

5. SETTING



WARNING

When setting parameters, do not turn off the SDAU alarm unit.

■ Items to Confirm before Start of Operation

Before you start operation, inspect and confirm the following items:

- (1) Draw out the internal unit from the rack case, and make sure that the specified fuses are properly mounted in the fuse holders at the rear of the internal unit.
Make sure that the specified power supply fuse is properly mounted in the fuse holder on the front for /TB option.
- (2) When inserting the internal unit into the rack case, firmly connect the multi-pin connectors for connecting the internal unit and the case.
- (3) Make sure that power plugs are properly connected to the power outlet.
- (4) Make sure that external wiring to the terminal block is properly connected.
- (5) Make sure the parameter setpoint, and change the setpoint if necessary. Set the parameter following the steps (1) through (3) described below.

Setting procedure required for basic use

- (1) Set the Input-Related Parameters.

For details on parameters, refer to Input-Related Parameters in Section 6.3, "Display on Front Panel: List of Parameters" or parameter numbers F** SET (I/O) in Section 6.4, "JHT200 Handy Terminal: List of Parameters."

For details on input processing function, refer to Section 4.2, "Input Processing Function."

- (2) Set the Alarm-Related Parameters.

Note: Alarm setting parameters (1H, 1L, 2H, 2L, 3H and 3L) are not displayed because they are not connected for factory-set default.

Set the alarm setpoint after completing the wiring for alarm.

For details on parameters, refer to Alarm Connection/Output Parameters and Alarm Detection-Related Parameters in Section 6.3, "Display on Front Panel: List of Parameters" or parameter numbers G** SET (ALM) and H** (ALM H/L) in Section 6.4, "JHT200 Handy Terminal: List of Parameters."

For details on the alarm processing function, refer to Section 4.3, "Alarm Processing Function."

Before defining the alarm setting parameters, determine the method of alarm connection by referring to Figure 4.5 "Alarm Processing Function Block Diagram" in Section 4.3, "Alarm Processing Function."

- (3) Set the Parameters for Optional Suffix Codes (for /VLT, /CUR or /COM only)

For details on parameters for "/VLT" or "/CUR" option, refer to Retransmission Output-Related Parameters in Section 6.3, "Display on Front Panel: List of Parameters" or parameter numbers J** SET (RET) in Section 6.4, "JHT200 Handy Terminal: List of Parameters."

For details on retransmission output function, refer to Section 4.4, "Retransmission

Output Function.”

For details on parameters for “/COM” option, refer to Communication-Related Parameters in Section 6.3, “Display on Front Panel: List of Parameters” or parameter numbers K** SET (COM) in Section 6.4, “JHT200 Handy Terminal: List of Parameters.”

For details on communication function, refer to Section 4.5, “Communication Function.”

- (4) Set the Point-of-error Failure Output Action Parameter (FAIL MODE).

(For options other than /RLY4, /MLT and /CUR)

For details on this parameter, see Section “Other Parameters” in 6.3, “Display on Front Panel: List of Parameters” or see parameter number F40 in Section 6.4, “JHT200 Handy Terminal: List of Parameters.”

For details on actions in case of failure, see Section 8.2, “Actions under Fault Conditions.”

5.1 Name of Components

The following shows the name of SDAU components.

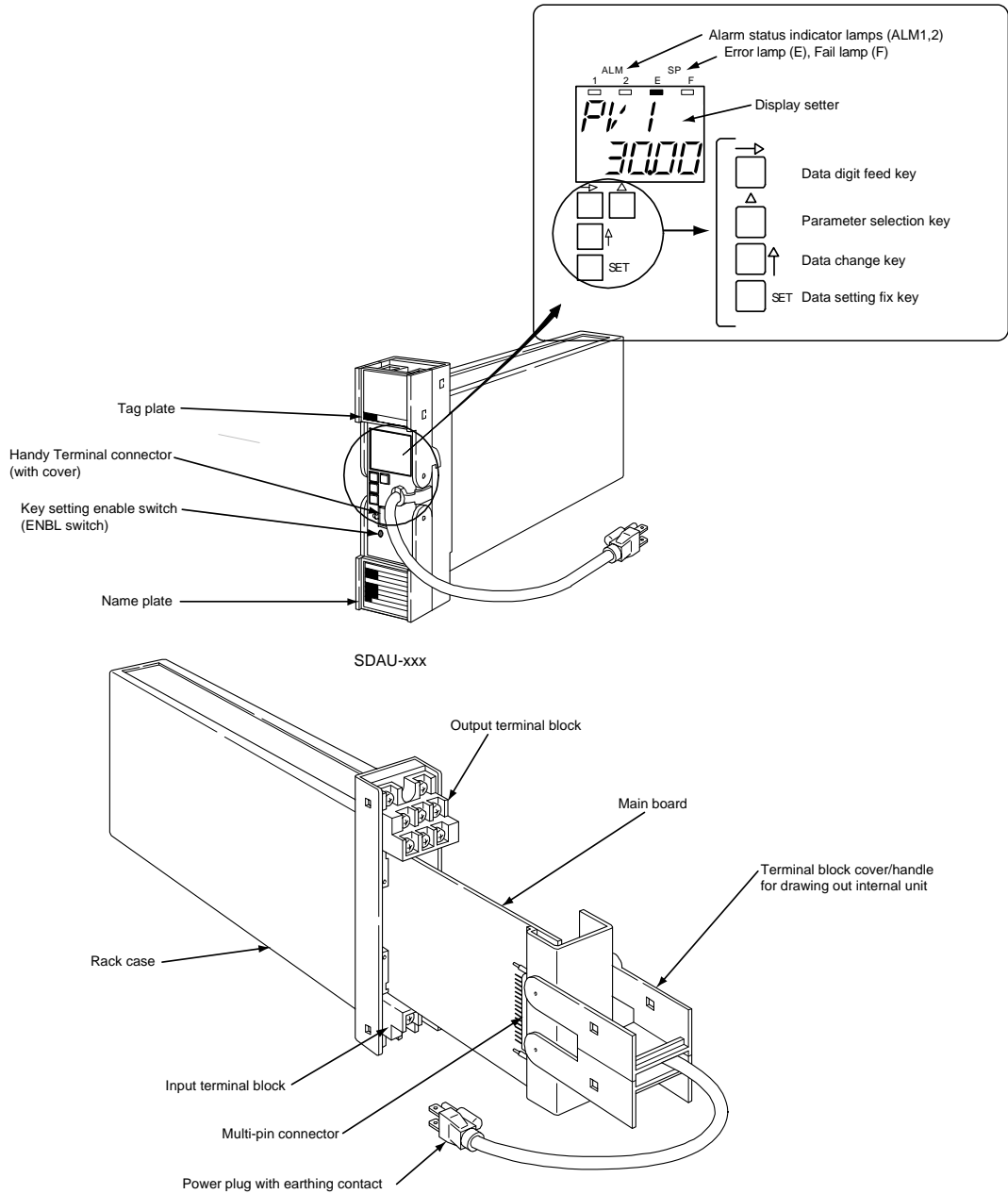

Figure 5.1 Names of Components

5.2 Part Names of the Display Setter

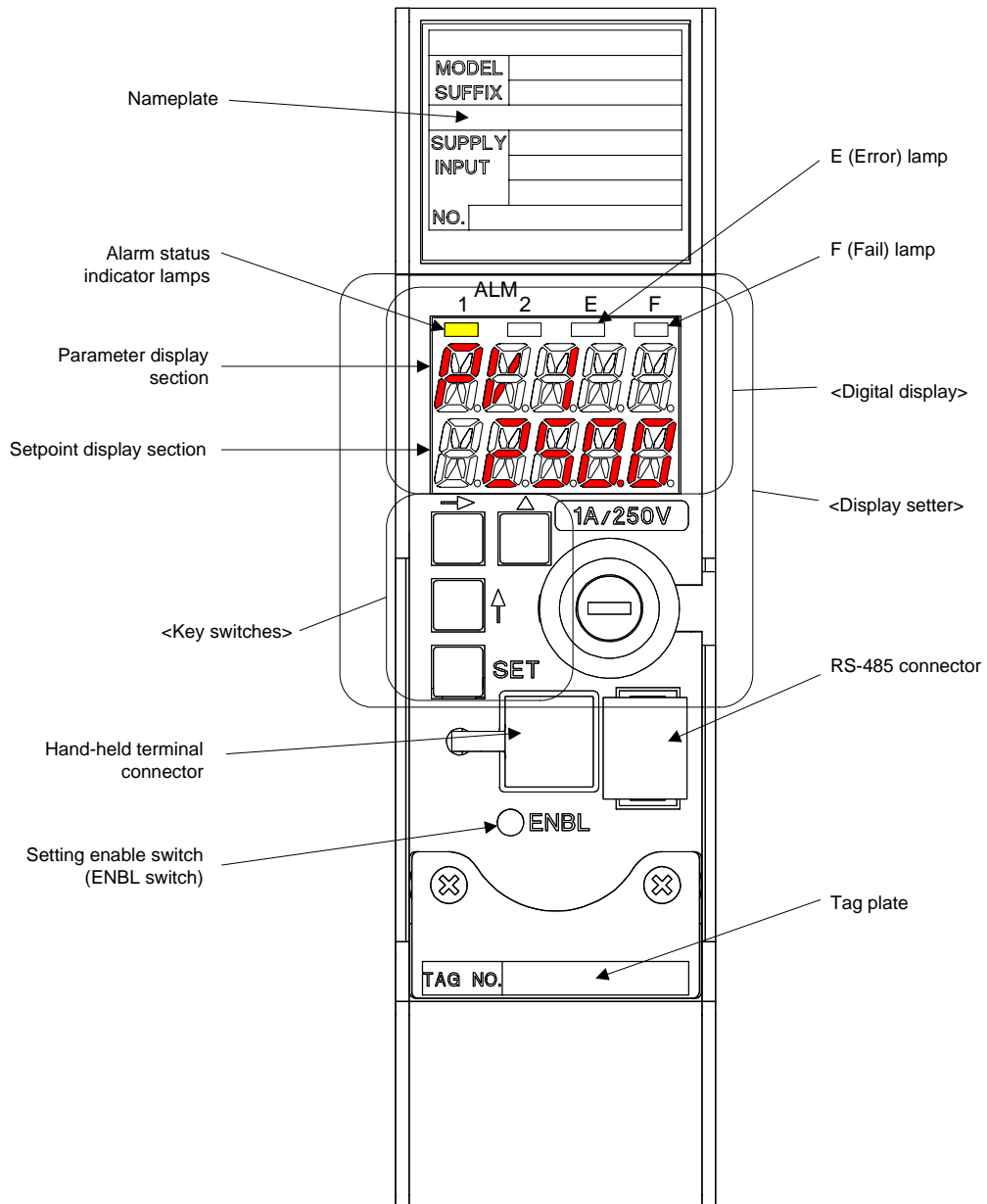
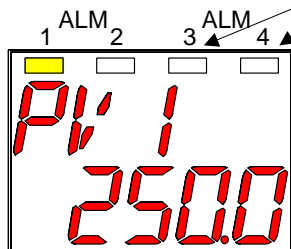

Figure 5.2 Part Names of the Display Setter

Note1 : When using the Handy Terminal, connect the Handy Terminal after removing the RS-485 connector.

Note2 : When the /RLY4 option is specified, the ALM3 and ALM4 lamps take the place of the E and F lamps.

<Digital display for /RLY4 option> ALM3 and ALM4 lamps (Alarm status indicator lamps)



■ Functions of the Digital Display Section

Table 5.1 Functions of the Digital Display Section

Display/indication	Function
Parameter display section	Displays a parameter symbol in an 11-segment indication. For the display of letters in 11 segments, see a List of LED Display Symbols in the following table.
Setpoint display section	Displays the status of a parameter displayed in the parameter display section (such as an input value, alarm status, self-diagnostic result) or setpoint.
ALM (Alarm-1 and -2 status indicator) lamps (yellow)	Light up in the event of an alarm.
ALM (Alarm-3 and -4 status indicator) lamps (yellow)	Provided only for the /RLY4 option. These lamps light up in the event of an alarm.
E (Error) lamp (yellow)	Not provided for the /RLY4 option. This lamp lights up in the event of an internal error such as input burnout. For more information, see Section 8.2, "Actions under Fault Conditions."
F (Fail) lamp (red)	Not provided for the /RLY4 option. This lamp lights up in the event of failure such as A/D conversion failure. For more information, see Section 8.2, "Actions under Fault Conditions."

■ List of LED Display Signal

Table 5.2 List of LED Display Signal

Alphabetic character	LED Display Signal	Alphabetic character	LED Display Signal	Numeral character	LED Display Signal
A		N		1	
B		O		2	
C		P		3	
D		Q		4	
E		R (Upper side digital indicator)		5	
		r (Lower side digital indicator)			
F		S		6	
G		T		7	
H		U		8	
I		V		9	
J		W		0	
K		X			
L		Y			
M		Z			

5.3 Setting Jumpers

The SDAU alarm unit has the following jumpers.

Table 5.3 Setting Jumpers

Name		Jumper Name	Optional Suffix
Parameter write-protect jumper		W.P.	
Alarm output contact action setting jumper	ALM1	RY.1	With /RLY4 specified
	ALM2	RY.2	With /RLY4 specified
	ALM3	RY.3	With /RLY4 specified
	ALM4	RY.4	With /RLY4 specified
Failure output contact action setting jumper			Without /RLY4, /VLT, or /CUR

- **Parameter write-protect jumper**
When this jumper is set to ON, key switch-based parameter changes, parameter changes via the JHT200 Handy Terminal, and RS-485 communication-based parameter changes will be disabled. In this case, pressing the [→] key switch with a setting parameter displayed on the digital display causes "LOCK" to appear in the upper half of the display setter. Press any key to return to the status that was set before the "LOCK" indication.
- **Failure output contact action setting jumper (jumper name: RY.4)**
Set this jumper only when the /RLY4, /VLT, or /CUR option is not specified. A failure output contact is always energized during normal operations. This jumper is used to set the action to be taken in the event of failure (for more information on CPU failure, and others, see Section 8.2, "Actions under Fault Conditions.").
For NC setting: Closed if a relay is de-energized.
For NO setting: Open if a relay is de-energized.
- **Alarm output contact action setting jumpers (jumper names: RY.1, RY.2, RY.3, RY.4)**
Set these jumpers if the /RLY4 option is specified. ALM1 is set with RY.1, ALM2 with RY.2, ALM3 with RY.3, and ALM4 with RY.4.
For NC setting: Closed if the relay is de-energized.
For NO setting: Open if the relay is de-energized.

5.3.1 Checking Setting Jumpers and their Locations

The setting jumpers are located on the main board of the internal unit.

Pull out the internal unit and check the current settings.

Moreover, the current status of the parameter write-protect jumper can be checked via the JHT200 Handy Terminal without pulling the internal unit out.

Jumper Name	JHT200 Parameter Name
Parameter write protect	A55: WRT PROTECT

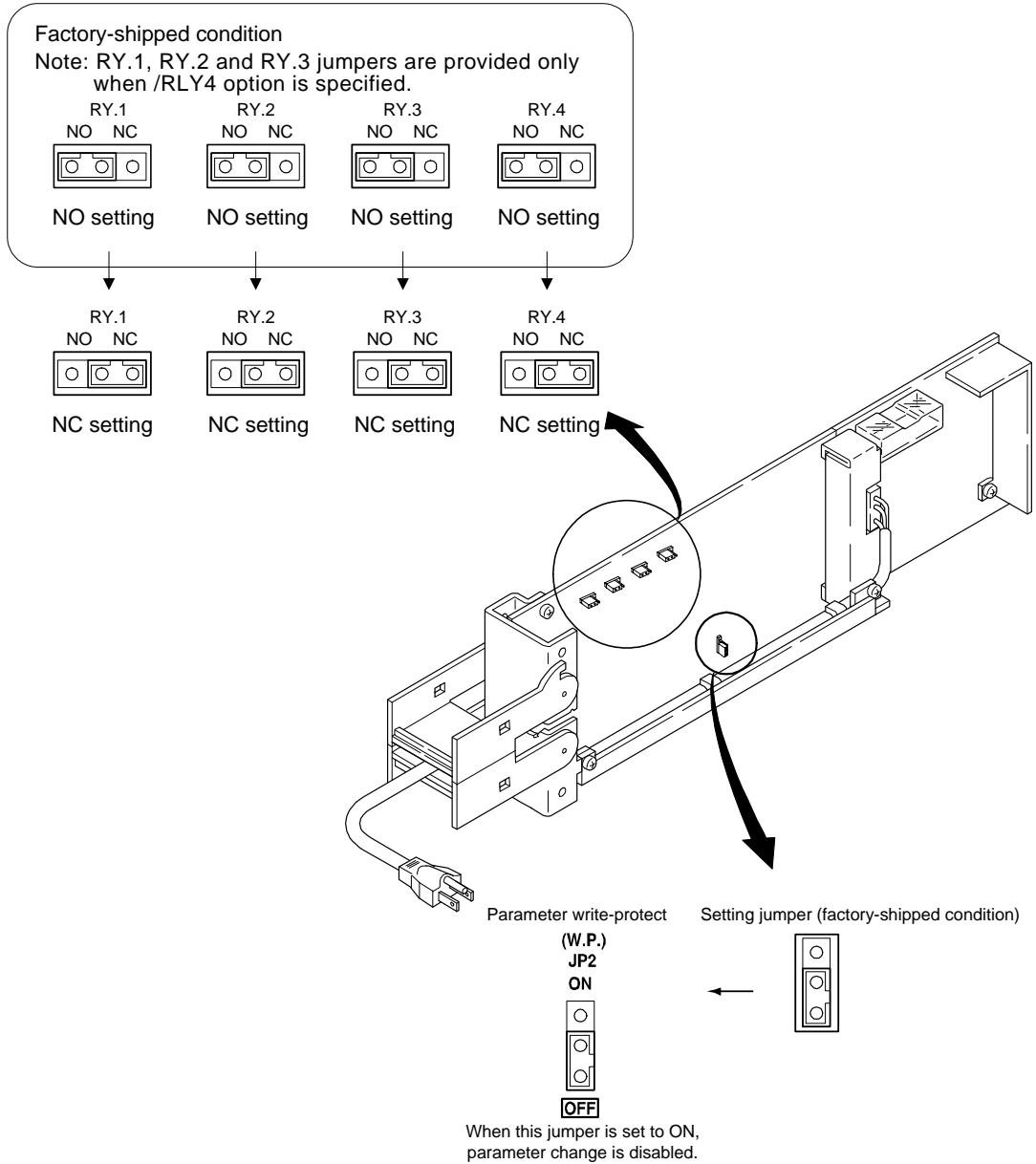

Figure 5.3 Jumper Settings

5.3.2 Change of Setting Jumper

Follow the procedure below to change the setting jumpers :

- (a) Pull the terminal block cover toward you to draw out the internal unit from the rack case.
- (b) Check the jumpers on the main board of the internal unit, and change their settings as desired. Use tweezers or another fine-tipped object to change the setting jumpers.
- (c) Return the internal unit to the rack case.
- (d) Return the terminal block cover to its original position.

5.4 Settings Done from the Front Panel of the Alarm Unit

Using the display setter on the front panel of the alarm unit, you can display input values and set parameters. For more information on the parameters, see Section 6.3, "Display on Front Panel: List of Parameters."

5.4.1 How to Operate the Key Switches

Table 5.4 Key Switch Functions

Key Switch	Functions			
	Display Mode	Setting Change Mode	Setting Fix Mode	Display Shutoff Mode
△	Displays the next parameter.	Cancels a changed value, returns the SDAU to display mode, and displays the next parameter.	Cancels a changed value, returns the SDAU to display mode, and displays the next parameter.	The SDAU enters this mode if a key switch is not operated for more than 30 min. while the display mode parameter is set to 0 = OFF. When a key switch is pressed in display shutoff mode, the SDAU returns to display mode.
→	Advances the SDAU to detailed alarm status display mode when ALMn=1 is indicated. Advances the SDAU to error display mode if FLAG ≠ 0000 is indicated. Advances the SDAU to setting change mode when a settable or changeable parameter is displayed in setting and change enable state. (Note 1)	Moves digit for setting.	Returns the SDAU to setting change mode and moves flashing to the next digit.	
↑	Displays the previous parameter.	Changes a setpoint.	No operation	
SET	Cancels disabled HOT start impossible status flag when FLAG parameter is displayed.	Advances the SDAU to setting fix mode.	Fixes a setpoint and advances the SDAU to display mode.	
Enable (ENBL)	The SDAU enters a setting-and-change enable state. If a password has been set, the SDAU enters a setting-enable state only when a correct password has been entered after pressing the ENBL switch. If the Parameter Write-Protect jumper has been set to ON, the ENBL switch will be disabled.			

Note 1: If the Parameter Write-Protect jumper on the main board has been set to ON, the SDAU does not advance to the setting change mode, but displays "LOCK" in the upper half of the digital display.

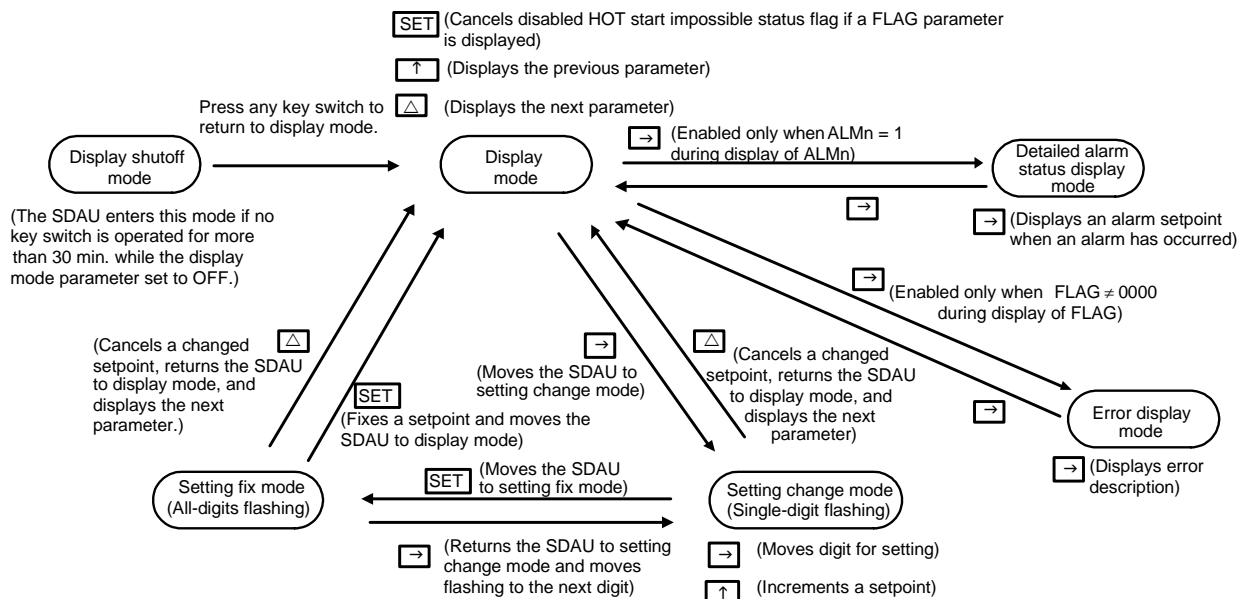

Figure 5.4 Key Switch Operations and Mode Transitions

5.4.2 Settings Using Key Switches (Example)

The following describes how to set a parameter using the key switches. Put the SDAU into a parameter setting-and-change enable state and follow the procedure below to set the parameter.



CAUTION

If the Parameter Write-Protect jumper on the main board has been set to ON, the SDAU does not advance to the setting change mode even if you press the [→] key switch in step (4) of the parameter setting procedure. Thus, the flashing indicator cannot move to the next digit. In this case, "LOCK" appears in the upper half of the digital display. To return to the display mode, press any key switch.

■ Parameter Setting Procedure

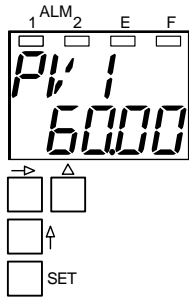

(1) An input value (60.00) appears at power ON.

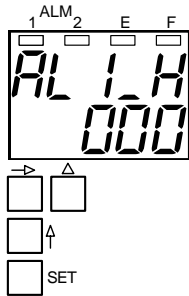

(2) Press the ENBL switch to bring about a setting and the change enable state.

(3) Alarm-1 high-limit alarm connection (AL1_H) appears.

Press the [↑] key several times.

(4) Set alarm-1 high-limit alarm connection (AL1_H).

Press the [→] key once. → This causes the most significant digit of the display to flash. Continuing to press the key causes the flashing indicator to move to a digit on the right.

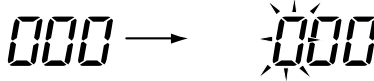

Press the [↑] key. → This causes the value of a flashing digit to increment. Press this key to bring about "1."

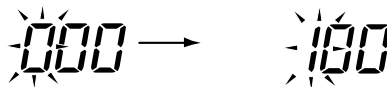

Press the [SET] key. → This causes all the digits to flash. Press the [SET] key again to cause "100" to light up. (This completes the setting.)

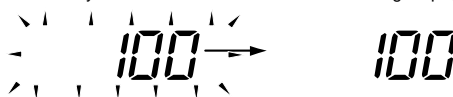

Figure 5.5 Parameter Setting Procedure

5.5 Parameter Change Disable Function

The SDAU alarm unit has four parameter-change-disable functions as shown in the table below. They are used to prevent a parameter from being changed inadvertently.

Table 5.5 Parameter Change Disable Function

	How to set disable function	How to cancel disable function	Operations to be disabled
Parameter Write-Protect jumper	Set the jumper (W.P.) on the main board to ON.	Set the jumper (W.P.) on the main board to OFF.	- Change of a parameter using key switches - Change of a parameter via the Handy Terminal - Change of a parameter through RS-485 communication
ENBL switch	If no key switch is operated for 30 min. since the last operation of a key switch on the front panel in the setting-and-change enable state, the SDAU enters the change disable state.	Press ENBL switch.	- Change of a parameter using key switches
Password parameter	Set a password using the SET parameter.	Enter a correct password to the PASS parameter.	- Change of a parameter using key switches
COMMU parameter	Set the COMMU parameter to "1."	Set the COMMU parameter to "0."	- Change of a parameter through RS-485 communication

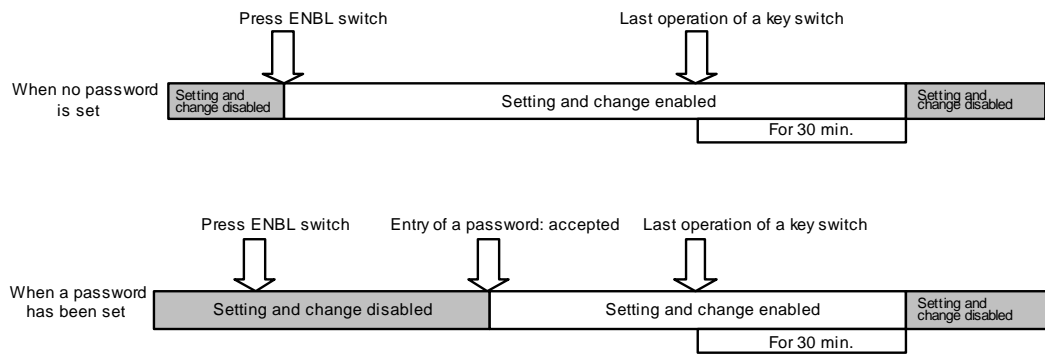

Figure 5.6 Relationship between the ENBL Switch and Password Function

5.6 Various Display Modes

This section describes various display modes.

5.6.1 Display at Power ON

The model with display setter displays REV NO. (revision number of software for the SDAU) for about 2 seconds after power ON.

Example of display (REV NO.2)



5.6.2 LOCK Display

If the upper half of the digital display shows "LOCK," the Parameter Write-Protect jumper on the main board has been set to ON. Thus, no parameters can be set or changed. The lower half of the digital display indicates nothing. Press any key switch to return to the status that was set before "LOCK" was displayed.

5.6.3 Display in Display Shutoff Mode

If the upper and lower halves of the digital display show decimal points only, the SDAU is in the display shutoff mode. This mode is activated if no key switch is operated for more than 30 minutes with the display mode parameter (DSPM) set to 0 = OFF.

To return to the display mode, press any key switch in the display shutoff mode.

If an A/D conversion failure, EEPROM failure, EEPROM SUM failure or RJC error occurs in the display shutoff mode, error indication has priority over the display shutoff mode.

Moreover, during the occurrence of an A/D conversion failure, EEPROM failure, EEPROM SUM failure or RJC error, the SDAU does not enter the display shutoff mode.

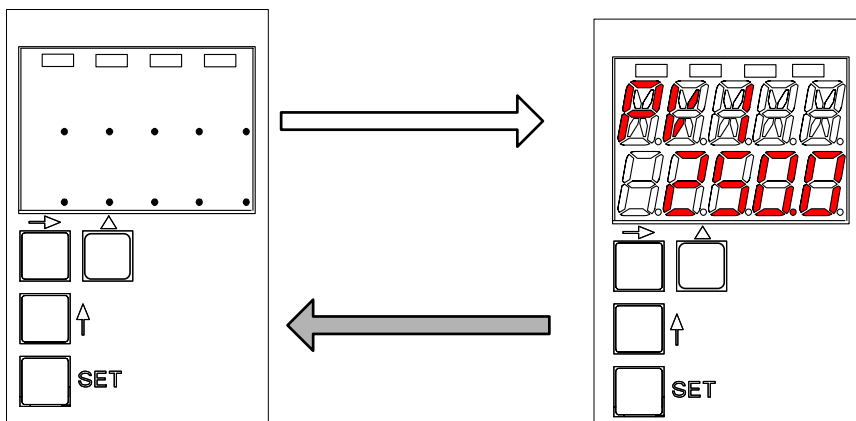

Figure 5.7 Display in Display Shutoff Mode

5.6.4 Error Display

When the upper half of the digital display shows a PV parameter (PVn, DV, PVn.VL), the lower half of the digital display indicates an error description. For more information, see Section 8.2, "Actions under Fault Conditions."

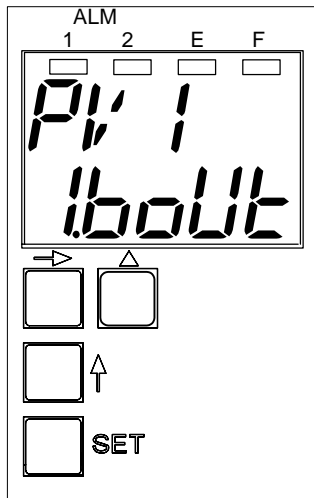

Figure 5.8 Error Display

5.6.5 Display of Self-Diagnostic Results

If the result of self-diagnosis (FLAG) is any value other than "0000," pressing the [→] key switch while the FLAG parameter is displayed causes the upper half of the digital display to show an error description. Nothing appears on the lower half of the digital display.

If multiple errors are present, press the [→] key switch to show the description of the next error. For more information, see Section 8.2, "Actions under Fault Conditions."

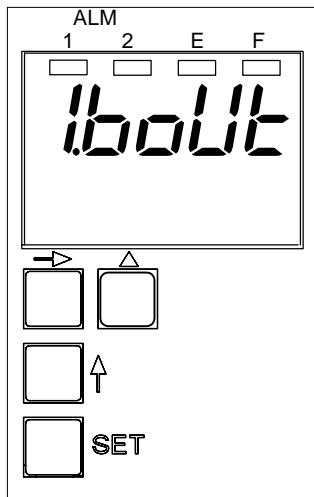

Figure 5.9 Display of Self-diagnostic Results

5.6.6 Detailed Alarm Status Display

The detailed alarm status display shows the type of input for which alarm has occurred and the relevant alarm setpoint.

To switch to the detailed alarm status display, press the [→] key switch while the alarm status is "1." Each time the [→] key switch is pressed, the display switches to the next alarm status by the number of alarm setpoints where an alarm has occurred.

The Detailed Alarm Status Display is not updated until the [→] key switch is pressed the next time.

Note: In the detailed alarm status display, you cannot change an alarm setpoint. Information provided on the Detailed Alarm Status Display is not updated even if the on-display alarm is canceled when the display is active. Nor is the information updated even if the on-display alarm setpoint is changed by parameter setting via BRAIN or RS-485 communication.

The display condition is as shown in the figure below.

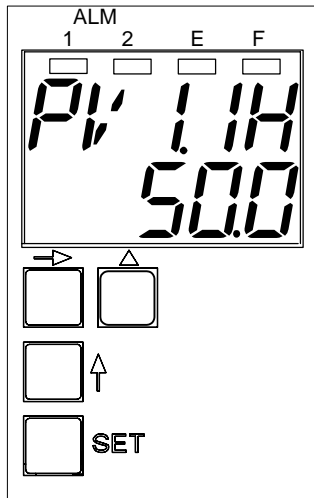

Figure 5.10 Display Condition of Detailed Alarm Status Display

1. Upper three digits of the upper half of digital display: Shows the input connected to an alarm point where an alarm has occurred.(PV1, PV2, DV, VL1, VL2)
2. Lower two digits of the upper half of digital display: Shows the alarm setpoint (1H, 1L, 2H, 2L, 3H, and 3L) where an alarm has occurred.
3. Lower half of digital display: Shows the setpoint of an alarm point where an alarm has occurred.

The following shows an example of the detailed alarm status display.

Setting 1:

ALM1: ALM1 alarm is output if all of the following are generated: the high high-limit alarm (1H) of input 1, the high-limit alarm (3H) of input 1, and the high-limit alarm (2H) of input 2.

ALM2: ALM2 alarm is output if either the high-limit alarm (2H) or the low-limit alarm (2L) of input 2 is generated.

Setting 2:

ALM1: ALM1 alarm is output if one of the following is generated: the high high-limit alarm (1H) of input 1, the high-limit alarm (3H) of input 1, or the high-limit alarm (2H) of input 2 is generated.

ALM2: ALM2 alarm is output if either the high-limit alarm (2H) or the low-limit alarm (2L) of input 2 is generated.

Parameter of Handy Terminal

Number	Indicator	Setting 1	Setting 2
G02	AL1_H	111	111
G03	AL1_L	000	000
G04	AND.OR.1	AND	OR
G09	AL2_H	010	010
G10	AL2_L	010	010
G11	AND.OR.2	OR	OR
G30	MOD1	PV1	PV1
G33	MOD2	PV2	PV2
G36	MOD3	PV1	PV1
H01	1H	80	80
H03	2H	50	50
H04	2L	40	40
H05	3H	70	70

A19	ALM1	OFF	ON
A20	ALM2	ON	ON

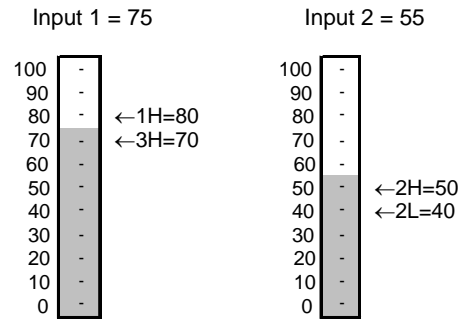

Figure 5.11 Detailed Alarm Status Display

The detailed alarm status display and its display procedure are as shown below when parameters in the table are set in an input condition as shown in the figure above.

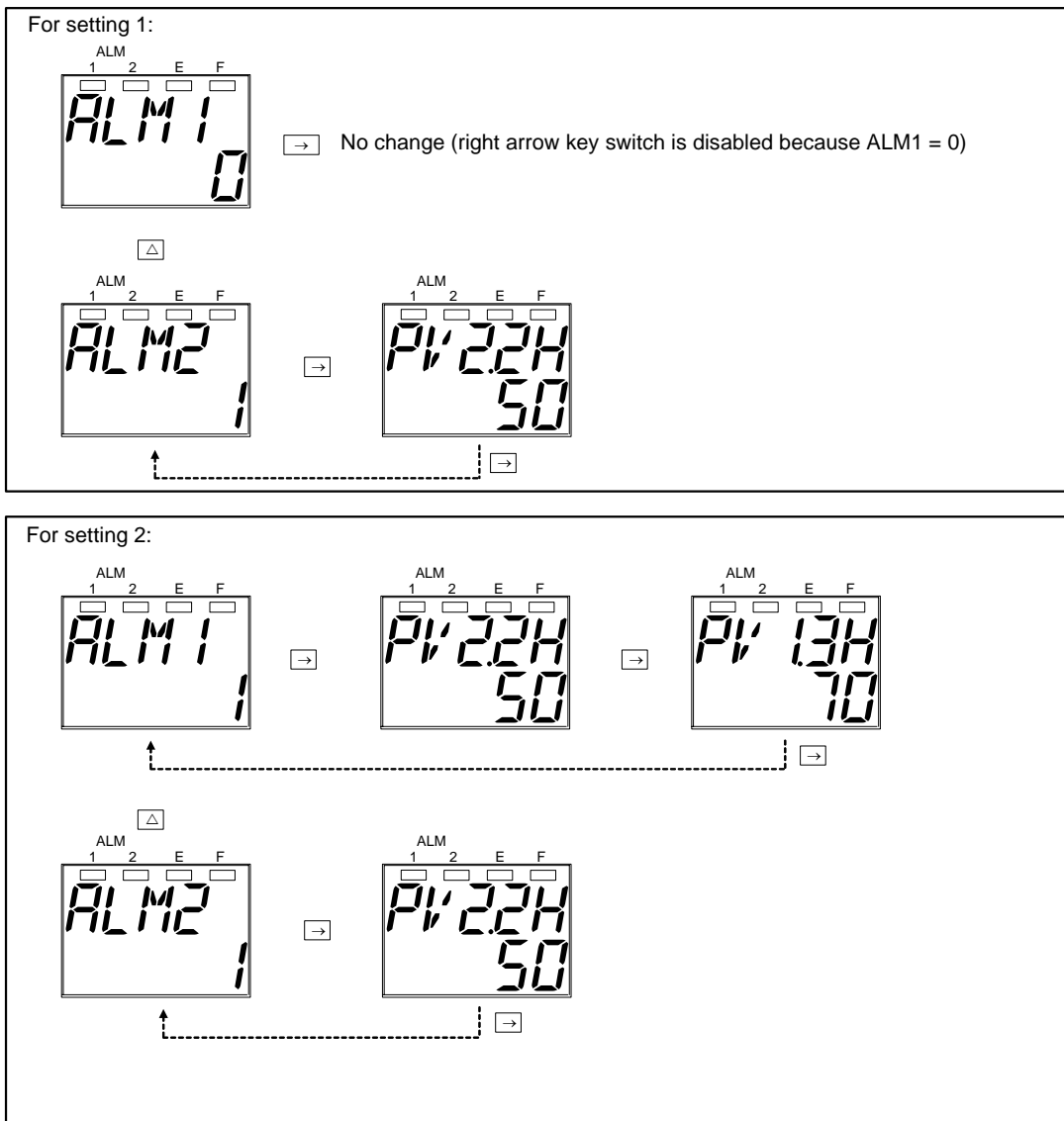

Figure 5.12 Examples of Detailed Alarm Status Display

5.7 Settings Using the JHT200 Handy Terminal

The SDAU alarm unit has BRAIN communication parameters used to specify a function or to adjust inputs/outputs. To display or set/change a parameter, connect the JHT200 Handy Terminal(*1) to this unit.

*1: The BT200 BRAIN Terminal of Yokogawa Electric Corporation can also be used.



NOTE

For details of operation and adjusting procedures of JHT200 Handy Terminal, refer to the instruction manual "JHT200 Handy Terminal" (IM JF81-02E).

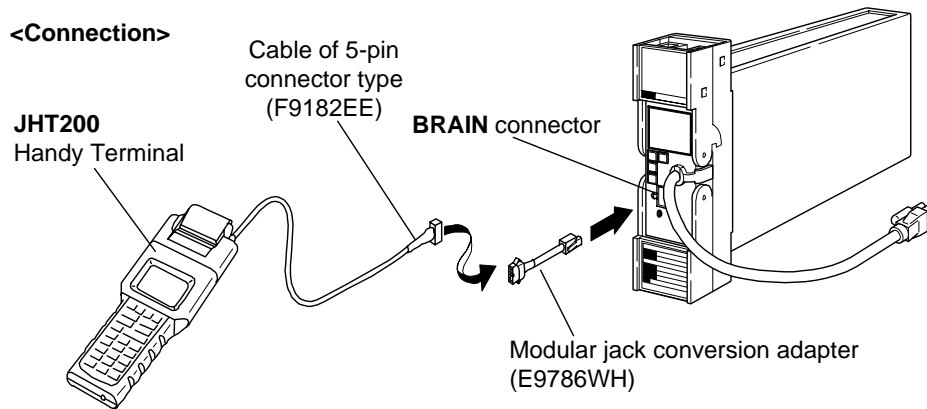

Figure 5.13 Connecting the Handy Terminal

6. PARAMETERS

6.1 Configuration of Parameters

The SDAU's parameters include display-only parameters (those shown in the shaded areas of the parameter chart) and parameters that can be set and changed.

A parameter can be set in two ways: one is to set it using the key switches and the other is to set it via the JHT200 Handy Terminal.

(For SDAU with the /COM option, a parameter can also be set through RS-485 communication.)

There are differences between the parameter symbols that are displayed on the display setter on the front panel of the unit and those that are displayed on the Handy Terminal due to some bearing on the display units. Moreover, there are also parameters that can be set only via the Handy Terminal. Parameters marked with "-" in Symbol appearing on digital display in Section 6.4, "JHT200 Handy Terminal: List of Parameters" are applicable to it.

Of parameters that can be set and changed, those required to be set at setup can be displayed on the display setter on the front panel by setting the SKIP parameter to "0."

If the SKIP parameter is set to "1," the parameters that can be set and changed, excepting alarm setpoints (1H, 2H, 3H, 1L, 2L, 3L), are not displayed on the display setter. The JHT200 Handy Terminal can display any parameters regardless of the setting of the SKIP parameter.

- Parameter to be displayed only
- Additional parameter from SDAU*E
- Parameter changed from SDAU*E

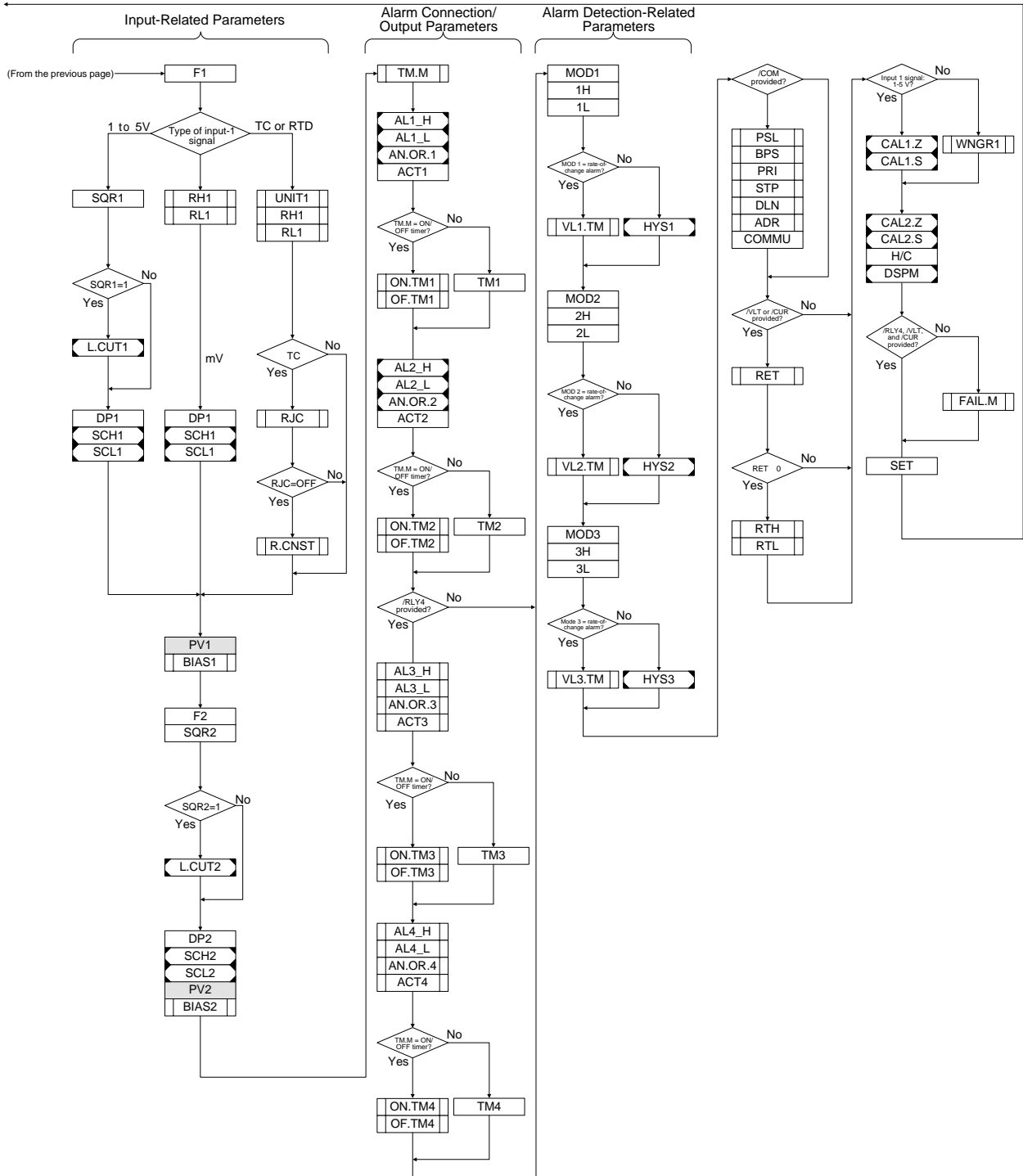

■ SDAU-270 Type Parameters

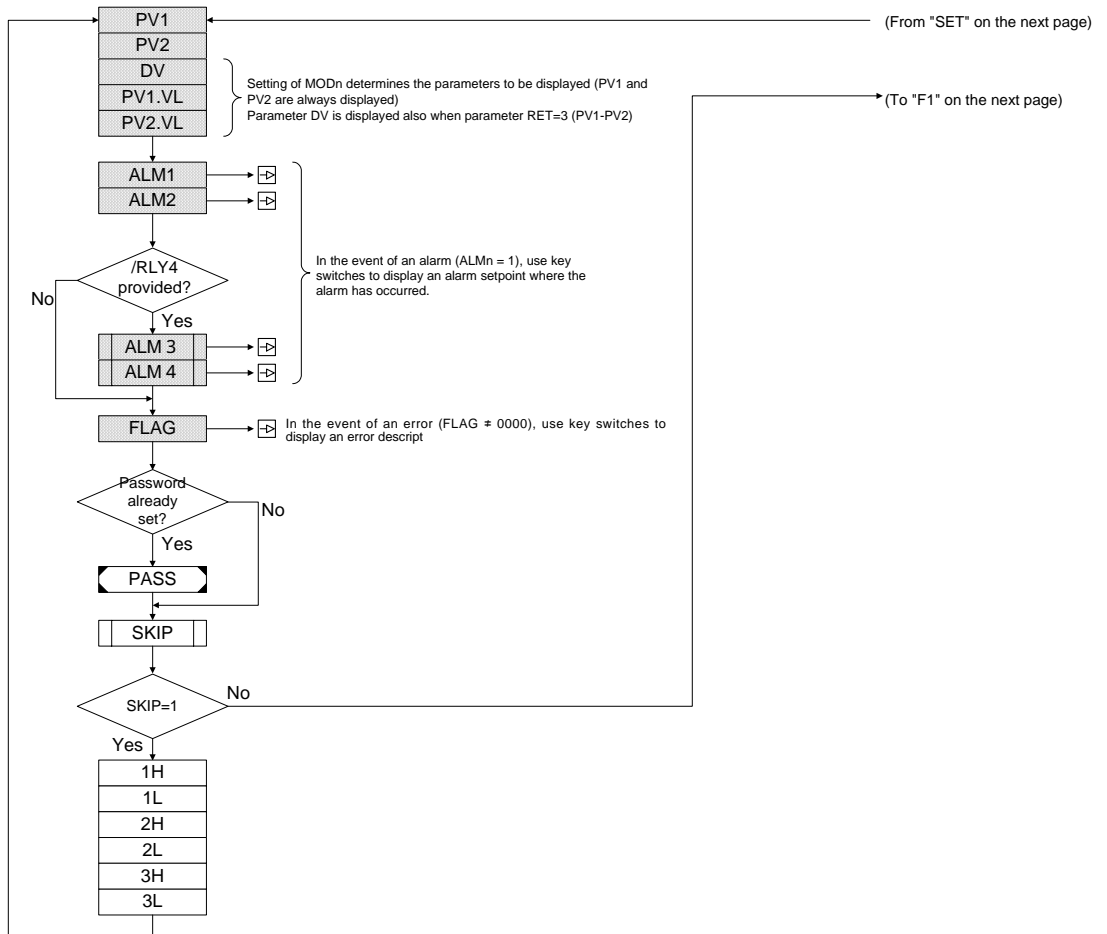
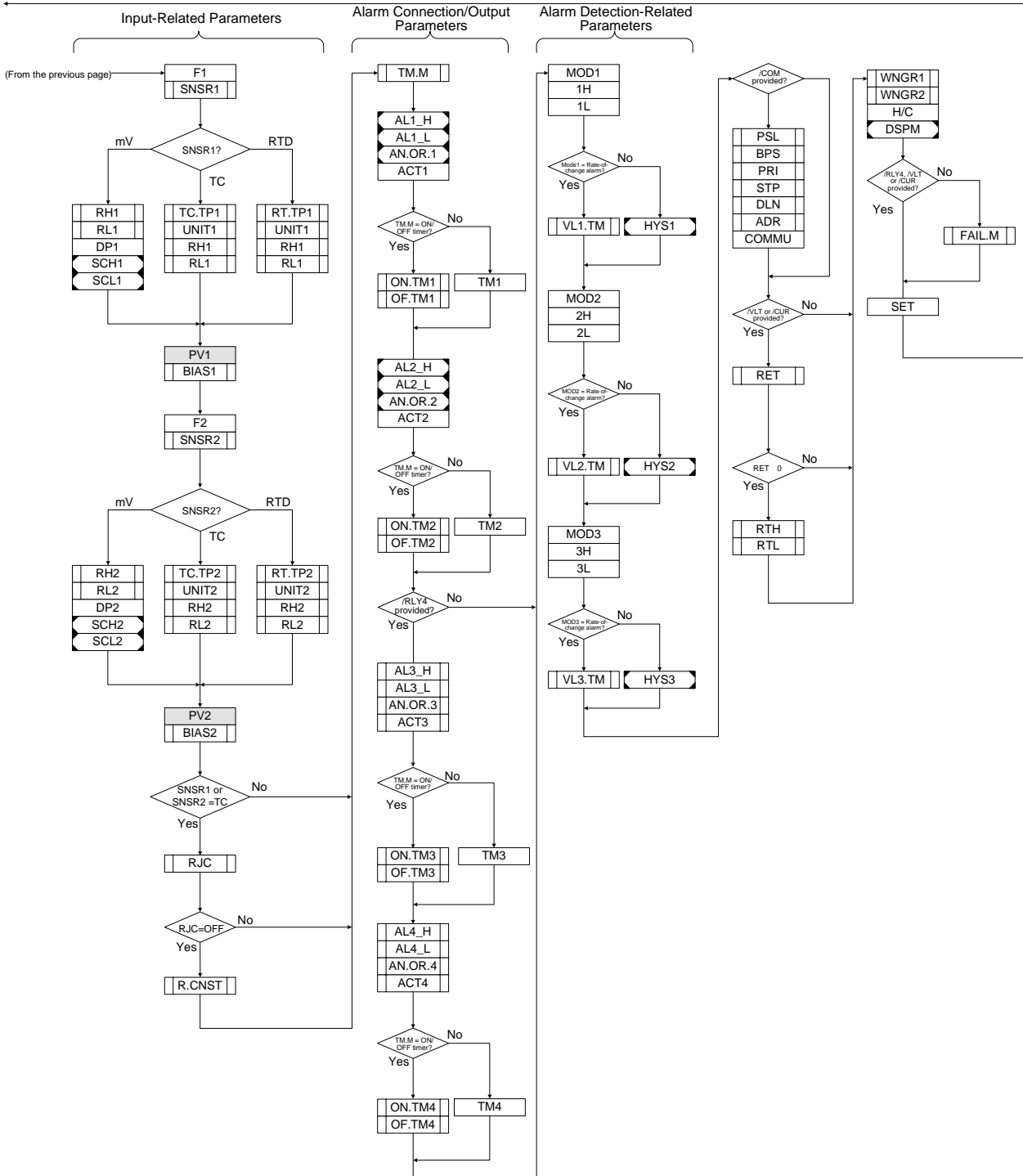
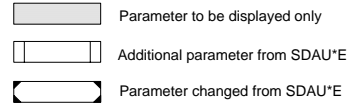

Figure 6.2 Chart of Parameters to be Displayed on SDAU-270 Type Front-Panel Digital Displays

Note: "nH" is displayed when an alarm is connected with ALn_H, while "nL" is displayed when it is connected with ALn_L.



6.3 Display on Front Panel: List of Parameters

There are parameters that are not displayed depending on the model, optional suffix code, or parameter's setpoint. For more information, see Section 6.2, "Display on Front Panel: Development View of Parameters."

When selecting a parameter for a choice using RS-485 communication, set a value given in the Description column in the table below.

■ Parameters to be Displayed Only

Symbol appearing on digital display		Item (Parameter Name)	Description	Display Range	Initial Value
SDAU*E	SDAU*R				
P1	PV1	PV1	Converts input 1 obtained after input processing, using SCH1 and SCL1 scales, to display.	-19999 to 32000	
P2	PV2	PV2	Converts input 2 obtained after input processing, using SCH2 and SCL2 scales, to display.	-19999 to 32000	
-	DV	DV (deviation)	Displays a value of PV1 - PV2	-19999 to 32000	
-	PV1.VL	PV1.VL (PV1 rate-of-change)	Displays a PV1 rate-of-change	-19999 to 32000	
-	PV2.VL	PV2.VL (PV2 rate-of-change)	Displays a PV2 rate-of-change	-19999 to 32000	
→ (Same as right)	ALM1	Alarm-1 status	Displayed if alarm 1 has occurred. 0: No alarm occurred 1: Alarm occurred In the event of an alarm, use key switches to display detailed alarm status.	0, 1	
→ (Same as right)	ALM2	Alarm-2 status	Displayed if alarm 2 has occurred. (Details are the same as those of alarm-1 status.)	0, 1	
-	ALM3	Alarm-3 status	Displayed if alarm 3 has occurred. (Details are the same as those of alarm-1 status.)	0, 1	
-	ALM4	Alarm-4 status	Displayed if alarm 4 has occurred. (Details are the same as those of alarm-1 status.)	0, 1	
→ (Same as right)	FLAG	Self-diagnostic result	Displays a value obtained by adding a value of self-diagnostic result (hex.). 0000: Normal 0001: Input-1 overrange 0002: Input-2 overrange 0004: A/D converter failure 0040: HOT start error 0080: EEPROM SUM failure 0100: EEPROM failure 0800: Input-1 burnout 1000: Input-2 burnout 8000: RJC error In the event of an error, use key switches to display the error description.	00 to FFFF	

■ Input-Related Parameters

Symbol appearing on digital display		Name (Parameter Name)	Description	Setting Range	Initial Value
SDAU*E	SDAU*R				
→ (Same as right)	F1	Input-1 filter	Sets first-order lag filter with respect to input 1. Approx. 0.1 sec. specific to hardware is added to this setting.	0.0 to 200.0 sec.	0.0 sec.
-	SNSR1	Sensor type 1	0: TC 1: mV 2: RTD	0 to 2	0 (Item to be specified when ordering)
→ (Same as right)	SQR1	Input-1 square root extraction	Sets the availability of square root extraction of input 1. 0: Not provided 1: Provided	0, 1	0
-	L.CUT1	Low-level cutoff point 1	Sets a low-level cutoff point to be applied when square root extraction of input 1 is available.	0.0 to 100.0%	1.0%
-	TC.TP1	Thermocouple type 1	1: Type K 2: Type E 3: Type J 4: Type T 5: Type R 6: Type S 7: Type B 8: Type N 9: Type W3 10: Type W5 Note: This parameter is initialized if SNSR1 changes.	1 to 10	1 (Item to be specified when ordering)
-	RT.TP1	RTD type 1	1: Pt100-90 (ITS-90, JIS'97) 2: Pt100-68 (ITS-68, JIS'89) 3: JPt100 (JIS'89) 4: Pt50 (JIS'81) Note: This parameter is initialized if SNSR1 changes.	1 to 4	1 (Item to be specified when ordering)
-	UNIT1	Unit 1	0: °C 2: °F 1: K	0, 1, 2	0
-	RH1	High limit of input-1 range	When input 1 is mV or temperature input, this parameter sets the high limit of the input-1 range. Setting range: mV input: -50.0 to 150.0 Temperature input: Measuring range, provided that RL1 < RH1 Initial value: (Except for the universal input type, this item is to be specified at purchase.) mV input: 100.0 Temperature input: Max. value of measuring range Position of decimal point (Unit 1=°C or K): Type W3 or W5: 0 Types other than W3 or W5: 1 Position of decimal point (Unit 1=°F): Type B, R, S, W3 or W5: 0 Types other than the above: 1 Note: This parameter is initialized if SNSR1, TC.TP1, RT.TP1, or UNIT1 changes.	(See the Description column.)	(See the Description column.)

Symbol appearing on digital display		Name (Parameter Name)	Description	Setting Range	Initial Value
SDAU*E	SDAU*R				
-	RL1	Low limit of input-1 range	When input 1 is mV or temperature input, this parameter sets the low limit of the input-1 range. Setting range: mV input: -50.0 to 150.0 Temperature input: Measuring range, provided that RL1 < RH1 Initial value: (Except for the universal input type, this item is to be specified at purchase.) mV input: 0.0 Temperature input: Min. value of measuring range Position of decimal point (Unit1=°C or K): Type W3 or W5: 0 Types other than W3 or W5: 1 Position of decimal point (Unit1=°F): Type B, R, S, W3 or W5: 0 Types other than the above: 1 Note: This parameter is initialized if SNSR1, TC.TP1, RT.TP1, or UNIT1 changes.	(See the Description column.)	(See the Description column.)
→ (Same as right)	DP1	Decimal point position of input 1	Sets the decimal point positions of SCH1 and SCL1. 0:xxxx. (with no decimal place) 1:xxx.x (with one decimal place) 2:xx.xx (with two decimal places) 3:x.xxx (with three decimal places) Note: This parameter is initialized if SNSR1, TC.TP1, RT.TP1, or UNIT1 changes.	0 to 3	1
H1	SCH1	Input-1 scale H	Sets the conversion reference value when input 1 = span point (5 V for 1-5 V input or RH1 for mV input). Note: This parameter is initialized if SNSR1, TC.TP1, RT.TP1, or UNIT1 changes.	-9999 to 9999	100.0
L1	SCL1	Input-1 scale L	Sets the conversion reference value when input 1 = zero point (1 V for 1-5 V input or RL1 for mV input). Note: This parameter is initialized if SNSR1, TC.TP1, RT.TP1, or UNIT1 changes.	-9999 to 9999	0.0
-	RJC	Availability of input reference junction compensation	If input 1 or input 2 is thermocouple input, this parameter sets the availability of reference junction compensation. 0: Available 1: Not available	0, 1	0
-	R.CNST	Fixed value of RJC	When RJC is OFF, the setpoint of this parameter becomes valid. Reference junction temperature can be fixed to a certain value. Note: This parameter is initialized if SNSR1 or UNIT1 changes (reference temperature unit is UNIT1). If IN1 is any input other than TC and IN2 is TC, it is initialized if SNSR2 or UNIT2 changes (reference temperature unit is UNIT2).	-20.0 to 80.0°C 254.0 to 353.0K -4.0 to 176.0°F	0.0°C 273.1K 32.0°F
P1	PV1	PV1	Converts input 1 by SCH1 and SCL1 scales to display.	-	-
-	BIAS1	Input-1 bias	Adds bias value to a value obtained after input processing and displays it as PV1. Setting range: -19999 to 32000 Where, engineering unit span (EUS) =±10% Position of decimal point: DP1 Note: This parameter is initialized if SNSR1, TC.TP1, RT.TP1, or UNIT1, SCH1, or SCL1 changes. Moreover, it is initialized if an RH1 or RL1 changes when IN1 is temperature input.	(See the Description column.)	0

Symbol appearing on digital display		Name (Parameter Name)	Description	Setting Range	Initial Value
SDAU*E	SDAU*R				
→ (Same as right)	F2	Input-2 filter	Sets first-order lag filter with respect to input 2. (Details are the same as those of input-1 filter.)	0.0 to 200.0 sec.	0.0
-	SNSR2	Sensor type 2	0: TC 1: mV 2: RTD	0 to 2	0 (Item to be specified when ordering)
→ (Same as right)	SQR2	Input-2 square root extraction	Sets the availability of square root extraction of input 2. (Details are the same as those of input-1 square root extraction.)	0, 1	0
-	L.CUT2	Low-level cutoff point 2	Sets a low-level cutoff point to be applied when square root extraction of input 2 is available.	0.0 to 100.0%	1.0%
-	TC.TP2	Thermocouple type 2	(Details are the same as those of thermocouple type 1. Note: This parameter is initialized if SNSR2 changes.	1 to 10	1 (Item to be specified when ordering)
-	RT.TP2	RTD type 2	(Details are the same as those of RTD type 1. Note: This parameter is initialized if SNSR2 changes.	1 to 4	1 (Item to be specified when ordering)
-	UNIT2	Unit 2	0: °C 2: °F 1: K	0, 1, 2	0
-	RH2	High limit of input-2 range	When input 2 is mV or temperature input, this parameter sets the high limit of the input-2 range. (Details are the same as those of the high limit of input-1 range. Note: This parameter is initialized if SNSR2, TC.TP2, RT.TP2, or UNIT2 changes.	(See the Description column.)	(See the Description column.)
-	RL2	Low limit of input-2 range	When input 2 is mV or temperature input, this parameter sets the low limit of the input-2 range. (Details are the same as those of the low limit of input-1 range. Note: This parameter is initialized if SNSR2, TC.TP2, RT.TP2, or UNIT2 changes.	(See the Description column.)	(See the Description column.)
→ (Same as right)	DP2	Decimal point position of input 2	Sets the decimal point positions of SCH2 and SCL2. Note: This parameter is initialized if SNSR2, TC.TP2, RT.TP2, or UNIT2 changes. (Details are the same as those of the decimal point position of input 1.	0 to 3	1
H2	SCH2	Input-2 scale H	Sets the conversion reference value when input 2 = span point (5 V for 1-5 V input or RH2 for mV input). Note: This parameter is initialized if SNSR2, TC.TP2, RT.TP2, or UNIT2 changes.	-9999 to 9999	100.0
L2	SCL2	Input-2 scale L	Sets the conversion reference value when input 2 = zero point (1 V for 1-5 V input or RL2 for mV input). Note: This parameter is initialized if SNSR2, TC.TP2, RT.TP2, or UNIT2 changes.	-9999 to 9999	0.0
P2	PV2	PV2	Converts input 2 by SCH2 and SCL2 scales to display.	-	-

Symbol appearing on digital display		Name (Parameter Name)	Description	Setting Range	Initial Value
SDAU*E	SDAU*R				
-	BIAS2	Input-2 bias	Adds bias value to a value obtained after input processing and displays it as PV2. Setting range: -19999 to 32000 Where, engineering unit span (EUS) = $\pm 10\%$ Position of decimal point: DP2 Note: This parameter is initialized if SNSR2, TC.TP2, RT.TP2, or UNIT2, SCH2, or SCL2 changes. Moreover, it is initialized if an RH2 or RL2 changes when IN2 is temperature input.	(See the Description column.)	0

■ Alarm Connection/Output Parameters

Symbol appearing on digital display		Name (Parameter Name)	Description	Setting Range	Initial Value
SDAU*E	SDAU*R				
-	TM.M	Alarm timer mode	Sets alarm timer mode. 0: Alarm output timer (which delays alarm output, equivalent to SDAU*E.) 1: ON/OFF delay timer (alarm dead time)	0, 1	0
A	AL1_H	High-limit alarm connection of alarm 1	Sets connection of a high limit alarm to be output as alarm 1. ABC A: For 1H, 0: not connected, 1: connected B: For 2H, 0: not connected, 1: connected C: For 3H, 0: not connected, 1: connected Note: For settings through RS-485 communication 0: 000 1: 001 2: 010 3: 011 4: 100 5: 101 6: 110 7: 111 E.g.: when 1H and 3H are connected to ALM1, it is 101.	000 to 111	000
A	AL1_L	Low-limit alarm connection of alarm 1	Sets connection of a low limit alarm to be output as alarm 1. ABC A: For 1L, 0: not connected, 1: connected B: For 2L, 0: not connected, 1: connected C: For 3L, 0: not connected, 1: connected Note: For settings through RS-485 communication 0: 000 1: 001 2: 010 3: 011 4: 100 5: 101 6: 110 7: 111 E.g.: when 1L and 2L are connected to ALM1, it is 110.	000 to 111	000
AN/OR1	AN.OR.1	Alarm-1 AND/OR specification	Sets whether AL1_H- and AL1_L-based alarm connections (1H, 1L, 2H, 2L, 3H, and 3L connected to AL1_H or AL1_L) are AND-connected or OR-connected. 0: OR connected 1: AND connected	0, 1	0
→ (Same as right)	ACT1	Direction of alarm-1 relay action	Sets the direction of an alarm-1 relay action. 0: De-energized during normal operations 1: Energized during normal operations	0, 1	0
→ (Same as right)	TM1	Alarm-1 output timer	Sets the output delay time of alarm 1. Alarm is output after a set time has elapsed.	0 to 600 sec.	0 sec.
-	ON.TM1	Alarm-1 ON delay timer	Sets dead time between the instant alarm-1 becomes activated and the instant alarm is output.	0 to 999 sec.	0 sec.
-	OF.TM1	Alarm-1 OFF delay timer	Sets dead time between the instant alarm-1 was canceled and the instant alarm output is stopped.	0 to 999 sec.	0 sec.
B	AL2_H	High-limit alarm connection of alarm 2	Sets connection of a high limit alarm to be output as alarm 2. (Details are the same as those of the high-limit alarm connection of alarm 1.)	000 to 111	000

Symbol appearing on digital display		Name (Parameter Name)	Description	Setting Range	Initial Value
SDAU*E	SDAU*R				
B	AL2_L	Low-limit alarm connection of alarm 2	Sets connection of a low limit alarm to be output as alarm 2. (Details are the same as those of the low-limit alarm connection of alarm 1.)	000 to 111	000
AN/OR2	AN.OR.2	Alarm-2 AND/OR specification	Sets whether AL2_H- and AL2_L-based alarm connections are AND-connected or OR-connected. (Details are the same as those of the alarm-1 AND/OR specification.)	0, 1	0
→ (Same as right)	ACT2	Direction of alarm-2 relay action	Sets the direction of an alarm-2 relay action. 0: De-energized during normal operations 1: Energized during normal operations	0, 1	0
→ (Same as right)	TM2	Alarm-2 output timer	Sets the output delay time of alarm 2. (Details are the same as those of the alarm-1 output timer.)	0 to 600 sec.	0 sec.
-	ON.TM2	Alarm-2 ON delay timer	Sets dead time between the instant alarm-2 becomes activated and the instant alarm is output.	0 to 999 sec.	0 sec.
-	OF.TM2	Alarm-2 OFF delay timer	Sets dead time between the instant alarm-2 was canceled and the instant alarm output is stopped.	0 to 999 sec.	0 sec.
-	AL3_H	High-limit alarm connection of alarm 3	Sets connection of a high limit alarm to be output as alarm 3. (Details are the same as those of the high-limit alarm connection of alarm 1.)	000 to 111	000
-	AL3_L	Low-limit alarm connection of alarm 3	Sets connection of a low limit alarm to be output as alarm 3. (Details are the same as those of the low-limit alarm connection of alarm 1.)	000 to 111	000
-	AN.OR.3	Alarm-3 AND/OR specification	Sets whether AL3_H- and AL3_L-based alarm connections are AND-connected or OR-connected. (Details are the same as those of the alarm-1 AND/OR specification.)	0, 1	0
-	ACT3	Direction of alarm-3 relay action	Sets the direction of an alarm-3 relay action. (Details are the same as those of the direction of the alarm-1 relay action.)	0, 1	0
-	TM3	Alarm-3 output timer	Sets the output delay time of alarm 3. (Details are the same as those of the alarm-1 output timer.)	0 to 600 sec.	0 sec.
-	ON.TM3	Alarm-3 ON delay timer	Sets dead time between the instant alarm-3 becomes activated and the instant an alarm is output.	0 to 999 sec.	0 sec.
-	OF.TM3	Alarm-3 OFF delay timer	Sets dead time between the instant alarm-3 was canceled and the instant an alarm output is stopped.	0 to 999 sec.	0 sec.
-	AL4_H	High-limit alarm connection of alarm 4	Sets connection of a high limit alarm to be output as alarm 4. (Details are the same as those of the high-limit alarm connection of alarm 1.)	000 to 111	000
-	AL4_L	Low-limit alarm connection of alarm 4	Sets connection of a low limit alarm to be output as alarm 4. (Details are the same as those of the low-limit alarm connection of alarm 1.)	000 to 111	000
-	AN.OR.4	Alarm-4 AND/OR specification	Sets whether AL4_H- and AL4_L-based alarm connections are AND-connected or OR-connected. (Details are the same as those of the alarm-1 AND/OR specification.)	0, 1	0
-	ACT4	Direction of alarm-4 relay action	Sets the direction of the alarm-4 relay action. (Details are the same as those of the direction of the alarm-1 relay action.)	0, 1	0
-	TM4	Alarm-4 output timer	Sets the output delay time of alarm 4. (Details are the same as those of the alarm-1 output timer.)	0 to 600 sec.	0 sec.

Symbol appearing on digital display		Name (Parameter Name)	Description	Setting Range	Initial Value
SDAU*E	SDAU*R				
-	ON.TM4	Alarm-4 ON delay timer	Sets dead time between the instant alarm-4 becomes activated and the instant an alarm is output.	0 to 999 sec.	0 sec.
-	OF.TM4	Alarm-4 OFF delay timer	Sets dead time between the instant alarm-4 was canceled and the instant an alarm output is stopped.	0 to 999 sec.	0 sec.

■ Alarm Detection-Related Parameters

Symbol appearing on digital display		Name (Parameter Name)	Description	Setting Range	Initial Value
SDAU*E	SDAU*R				
→ (Same as right)	MOD1	Input mode 1	Sets a target input at alarm detection 1. 0: Input 1 1: Input 2 2: (Input 1 - Input 2) 3: Input 1 rate-of-change 4: Input 2 rate-of-change	0 to 4	0
→ (Same as right)	1H	High limit alarm setpoint 1H	Sets a high limit alarm at alarm detection 1. It is set in engineering units of an input connected through MOD1. Note: This parameter is initialized if SNSRn, TC.TPn, RT.TPn, DPn, SCHn, SCLn, UNITn, or MOD1 of the connected input changes. When the connected input is temperature input, it is initialized if RHn or RLn changes. Moreover, when MOD1 = 2, it is initialized if DP1 or DP2 changes. Displayed when 1H is connected to any of AL1_H, AL2_H, AL3_H and AL4_H. Initial value: When MOD1 = 0 or 1, 125% of scale (mV or 1-5 V input) Max. value of measuring range (thermocouple or RTD input) When MOD1 = 2, SCH1 (or max. value of measuring range) - SCL2 (or min. value of measuring range) When MOD1 = 3 or 4, 32000	-19999 to 32000 (For the decimal point position, see Table 6.2.)	(See the Description column.)
→ (Same as right)	1L	Low limit alarm setpoint 1L	Sets a low limit alarm at alarm detection 1. It is set in engineering units of an input connected through MOD1. Note: This parameter is initialized if SNSRn, TC.TPn, RT.TPn, DPn, SCHn, SCLn, UNITn, or MOD1 of the connected input changes. When the connected input is temperature input, it is initialized if RHn or RLn changes. Moreover, when MOD1 = 2, it is initialized if DP1 or DP2 changes. Displayed when 1L is connected to any of AL1_H, AL2_H, AL3_H and AL4_H. Initial value: When MOD1 = 0 or 1, -2.5% of scale (mV or 1-5 V input) Min. value of measuring range (thermocouple or RTD input) When MOD1 = 2, SCL1 (or min. value of measuring range) - SCH2 (max. value of measuring range) When MOD1 = 3 or 4, -19999	-19999 to 32000 (For the decimal point position, see Table 6.2.)	(See the Description column.)

Symbol appearing on digital display		Name (Parameter Name)	Description	Setting Range	Initial Value
SDAU*E	SDAU*R				
LW1	HYS1	Hysteresis 1	<p>Sets hysteresis at alarm detection 1. For the scale of reference, see Table 6.1. Setting range: 0 to 100% of engineering unit span (EUS)</p> <p>Note: For SDAU*E, hysteresis is set at 0 to 10% of span instead of setting it to engineering unit span.</p> <p>Position of decimal point: See Table 6.2.</p> <p>Note: This parameter is initialized if SNSRn, TC.TPn, RT.TPn, DPn, SCHn, SCLn, UNITn, or MOD1 of the connected input changes. When the connected input is temperature input, it is initialized if RHn or RLn changes. Moreover, when MOD1 = 2, it is initialized if DP1 or DP2 changes.</p> <p>Initial value: 2.0% of scaled span (EUS)</p>	0 to 32000 (See the Description column.)	(See the Description column.)
-	VL1.TM	Rate-of-change alarm-1 sampling time	<p>Sets change time if alarm detection 1 is a rate-of-change alarm, E.g.: if 10 sec. is set, the PV obtained 10 sec. before and the current PV are compared to obtain the rate of change, which is compared with the alarm setpoint.</p>	1 to 9999 sec.	1 sec.
→ (Same as right)	MOD2	Input mode 2	<p>Sets a target input at alarm detection 2. (Details are the same as those of input mode 1.)</p>	0 to 4	0
→ (Same as right)	2H	High limit alarm setpoint 2H	<p>Sets a high limit alarm at alarm detection 2. (Details are the same as those of alarm setpoint 1H.)</p> <p>Displayed when 2H is connected to any of AL1_H, AL2_H, AL3_H and AL4_H.</p>	-19999 to 32000 (For the decimal point position, see Table 6.2.)	(See the Description column.)
→ (Same as right)	2L	Low limit alarm setpoint 2L	<p>Sets a low limit alarm at alarm detection 2. (Details are the same as those of alarm setpoint 1L.)</p> <p>Displayed when 2L is connected to any of AL1_H, AL2_H, AL3_H and AL4_H.</p>	-19999 to 32000 (For the decimal point position, see Table 6.2.)	(See the Description column.)
LW2	HYS2	Hysteresis 2	<p>Sets hysteresis at alarm detection 2. (Details are the same as those of hysteresis 1.)</p> <p>Note: Setting range is 0 to 100% of the engineering unit span (EUS).</p>	0 to 32000 (See the Description column.)	(See the Description column.)
-	VL2.TM	Rate-of-change alarm-2 sampling time	<p>Sets change time if alarm detection 2 is a rate-of-change alarm, E.g.: if 10 sec. is set, the PV obtained 10 sec. before and the current PV are compared to obtain the rate of change, which is compared with the alarm setpoint.</p>	1 to 9999 sec.	1 sec.

Symbol appearing on digital display		Name (Parameter Name)	Description	Setting Range	Initial Value
SDAU*E	SDAU*R				
→ (Same as right)	MOD3	Input mode 3	Sets a target input at alarm detection 3. (Details are the same as those of input mode 1.)	0 to 4	0
→ (Same as right)	3H	High limit alarm setpoint 3H	Sets a high limit alarm at alarm detection 3. (Details are the same as those of alarm setpoint 1H.) Displayed when 3H is connected to any of AL1_H, AL2_H, AL3_H and AL4_H.	-19999 to 32000 (For the decimal point position, see Table 6.2.)	(See the Description column.)
→ (Same as right)	3L	Low limit alarm setpoint 3L	Sets a low limit alarm at alarm detection 3. (Details are the same as those of alarm setpoint 1L.) Displayed when 3L is connected to any of AL1_H, AL2_H, AL3_H and AL4_H.	-19999 to 32000 (For the decimal point position, see Table 6.2.)	(See the Description column.)
LW3	HYS3	Hysteresis 3	Sets hysteresis at alarm detection 3. (Details are the same as those of hysteresis 1.) Note: Setting range is 0 to 100% of the engineering unit span (EUS).	0 to 32000 (See the Description column.)	(See the Description column.)
-	VL3.TM	Rate-of-change alarm-3 sampling time	Sets change time if alarm detection 3 is rate-of-change alarm, E.g.: if 10 sec. is set, the PV obtained 10 sec. before and the current PV are compared to obtain the rate of change, which is compared with the alarm setpoint.	1 to 9999 sec.	1 sec.

■ Communication-Related Parameters (for /COM Option)

Symbol appearing on digital display		Name	Description	Setting Range	Initial Value
SDAU*E	SDAU*R				
-	PSL	Protocol selection	Specifies communication protocol 0: PC link 1: PC link (with checksum) 2: Ladder communication 3: MODBUS (ASCII) 4: MODBUS (RTU)	0 to 4	0
-	BPS	Communication rate	0: 1200 bps 1: 2400 bps 2: 4800 bps 3: 9600 bps	0 to 3	3
-	PRI	Parity	0: None 1: Even 2: Odd	0 to 2	1
-	STP	Stop bit	1: 1 bit 2: 2 bits	1, 2	1
-	DLN	Data length	7: 7 bits 8: 8 bits For protocols other than PC link, set this parameter to "8."	7 or 8	8
-	ADR	Instrument address	1 to 99	1 to 99	1
→ (Same as right)	COMMU	Specification of communication write protect	Specifies the disabling/enabling of parameter change through RS-485 communication. 0: Enable 1: Disable	0, 1	0

■ Retransmission Output-Related Parameters (for /VLT or /CUR Option)

Symbol appearing on digital display		Name	Description	Setting Range	Initial Value
SDAU*E	SDAU*R				
-	RET	Selection of retransmission output type	Specifies input to be output as retransmission output. 0: Does not use retransmission output. 1: Outputs PV1. 2: Outputs PV2. 3: Outputs deviation (PV1 - PV2).	0 to 3	0
-	RTH	Max. value of retransmission output scale	Specifies the maximum value of the retransmission output scale. Note: This parameter is initialized if SNSRn, TC.TPn, RT.TPn, SCHn, SCLn, UNITn, or RET of input specified for RET changes. When input specified for RET is temperature input, it is initialized if RHn or RLn changes. Moreover, when RET = 3, it is initialized if DP1 or DP2 changes. Initial value: When RET = 1 or 2, SCHn for 1-5 V or mV input RHn for temperature input When RET = 3 SCH1 - SCL2 for 1-5 V or mV input RH1 - RL2 for temperature input	-19999 to 32000 (For the decimal point position, see Table 6.2)	(See the Description column.)
-	RTL	Min. value of retransmission output scale	Specifies the minimum value of the retransmission output scale. Note: This parameter is initialized if SNSRn, TC.TPn, RT.TPn, SCHn, SCLn, UNITn, or RET of input specified for RET changes. When input specified for RET is temperature input, it is initialized if RHn or RLn changes. Moreover, when RET = 3, it is initialized if DP1 or DP2 changes. Initial value: When RET = 1 or 2, SCLn for 1-5 V or mV input RLn for temperature input When RET = 3 SCL1 - SCH2 for 1-5 V or mV input RL1 - RH2 for temperature input	-19999 to 32000 (For the decimal point position, see Table 6.2.)	(See the Description column.)

■ Adjustment-related Parameters

Symbol appearing on digital display		Name	Description	Setting Range	Initial Value
SDAU*E	SDAU*R				
-	WNGR1	Correction of input-1 wire resistance	Corrects the wire resistance of input 1. 0: RESET 1: EXECUTE Note 1: This parameter is initialized if BURNOUT1, SENSOR TYPE1, TC TYPE1, or RTD TYPE1 changes.	0, 1	0
-	WNGR2	Correction of input-2 wire resistance	Corrects the wire resistance of input 2. 0: RESET 1: EXECUTE Note 1: This parameter is initialized if BURNOUT2, SENSOR TYPE2, TC TYPE2, or RTD TYPE2 changes.	0, 1	0
CAL1_Z	CAL1.Z	Input-1 zero CAL	Gives instructions to make a zero-point (1 V) calibration of input 1. Enter a zero point in input 1 and set parameter to "1." This causes the input of that time to become a new reference value for A/D conversion. This process takes approx. 1 sec. and when it finishes, the reading returns to "0." Note: If a relevant input is deviated from the internal reference zero point, exceeding 1% of span, no calibration will be made and a value reached just before the end of the setting remains unchanged. At this time the digital display flashes. In this case, re-enter a zero point to make the setting again. It is also possible to cancel the setting. Note: The adjusted internal value of this parameter is initialized if SNSR1, TC.TP1, or RT.TP1 changes.	0, 1	0
CAL1_S	CAL1.S	Input-1 span CAL	Gives instructions to make a span point (5 V) calibration of input 1. Enter a span point in input 1 and set parameter to "1." This causes the input of that time to become a new reference value for A/D conversion. This process takes approx. 1 sec. and when it finishes, the reading returns to "0." Note: If a relevant input is deviated from the internal reference span point, exceeding 1% of span, no calibration will be made and a value reached just before the end of the setting remains unchanged. At this time the digital display flashes. In this case, re-enter the span point to make the setting again. It is also possible to cancel the setting. Note: The adjusted internal value of this parameter is initialized if SNSR1, TC.TP1, or RT.TP1 changes.	0, 1	0
CAL2_Z	CAL2.Z	Input-2 zero CAL	Gives instructions to make a zero-point (1 V) calibration of input 2. (Details are the same as those of input-1 zero CAL.) Note: The adjusted internal value of this parameter is initialized if SNSR2, TC.TP2, or RT.TP2 changes.	0, 1	0
CAL2_S	CAL2.S	Input-2 span CAL	Gives instructions to make a span point (5 V) calibration of input 2. (Details are the same as those of input-1 span CAL.) Note: The adjusted internal value of this parameter is initialized if SNSR2, TC.TP2, or RT.TP2 changes.	0, 1	0

■ Other Parameters

Symbol appearing on digital display		Name	Description	Setting Range	Initial Value
SDAU*E	SDAU*R				
PWD	PASS	Password tuning	Checks a password against a specified one. If a value other than "0000" has been set in SET, entering that value to this parameter allows parameters to be set or changed using the key switches. This value is reset to "0000" if no key switch is operated for 30 minutes. Moreover, it is always "0000" at re-power ON. This parameter is not provided for the JHT200 Handy Terminal.	0000 to 9999	(0000)
-	SKIP	Parameter invisibility setting	Makes setting so that set parameters other than the alarm setpoints are not displayed on the digital display. 0: Displays all parameters. 1: Makes parameters other than 1H, 1L, 2H, 2L, 3H, and 3L (PWD) invisible on digital display. (Even when SKIP=1 has been set, the Handy Terminal displays all parameters.)	0, 1	0
→ (Same as right)	H/C	HOT start/COLD start	Specifies the start mode to be applied at power ON. 0: COLD start 1: HOT start	0, 1	0
DSPMOD	DSPM	Display mode	Specifies whether to turn ON/OFF the digital display when 30 min. elapses after the last operation of a key switch. 0: OFF, or display shutoff mode The digital display shows only decimal points if no key switch is operated for 30 min. 1: ON, or continuous light mode Data(*) is always displayed regardless of the elapsed time of no key switch operation. *: Data to display is the parameter displayed at the last operation of a key switch.	0, 1	0
-	FAIL.M	Point-of-error failure output action	Specifies the action of the failure output contact to be taken in case of a failure where the E lamp comes on (input 1 burnout, input 2 burnout, input 1 overrange, input 2 overrange or inability to make HOT start) 0: Failure output provided (same as with SDAU*E) 1: Failure output not provided	0, 1	0
→ (Same as right)	SET	Password setting	Sets a password. Setting a value other than "0000" to this parameter causes a parameter not to be set or changed from the front panel. Setting "0000" to the parameter cancels a password set status. After setting a password, display returns to "0000" immediately. This parameter is not provided for the JHT200 Handy Terminal. Take care not to forget the set password. To cancel a password, contact your nearest YOKOGAWA representative. (Note that this is a charged service.)	0000 to 9999	0000

6.4 JHT200 Handy Terminal: List of Parameters



NOTE

The SET parameters and PASS parameter cannot be displayed or set using the JHT200 Handy Terminal.

If any parameter value is read using the Handy Terminal with the Parameter Write Protect jumper (W.P.) set to ON, the data lines of parameters with the value 0 become blank.

JHT200 Handy Terminal								
Symbol Appearing on Digital Display	Symbol	No.	Display	Item	Description	Display Condition		
			Initial display					
-		01	MODEL	Model	Displays a model.	Always displayed		
-		02	TAG NO	Tag no.	Displays a tag number if set.			
-		03	SELF CHK	Self-diagnostic result	Displays the self-diagnostic result as "GOOD" or "ERROR."			
	A		DISPLAY1	Display 1				
-		A01	INPUT1	Analog input 1	The value of input 1 before input processing (filter, square root extraction, and scaling)	Input 1 is 1-5 V input.		
-		A02	INPUT2	Analog input 2	The value of input 2 before input processing (filter, square root extraction, and scaling)	Input 2 is 1-5 V input.		
PV1		A03	PV1	See Display on Front Panel: List of Parameters.		Always displayed		
PV2		A04	PV2			Always displayed		
DV		A05	DV			MOD1, MOD2, or MOD3 is a deviation alarm. Alternatively, RET=PV1-PV2.		
PV1.VL		A06	PV1.VL			MOD1, MOD2, or MOD3 is a PV1 rate-of-change alarm.		
PV2.VL		A07	PV2.VL			MOD1, MOD2, or MOD3 is a PV2 rate-of-change alarm.		
ALM1		A19	ALM1			See Display on Front Panel: List of Parameters.	Displays OFF/ON. "ON" appears in the event of an alarm.	Always displayed
ALM2		A20	ALM2					
ALM3		A21	ALM3	/RL4				
ALM4		A22	ALM4					
FLAG		A53	FLAG	See Display on Front Panel: List of Parameters.		Always displayed		
-		A55	WRT PROTECT	Parameter write protect	Displays the status of the Parameter Write-Protect jumper setting. OFF: Parameters can be set from JHT200. ON: Parameters cannot be set from JHT200.	Always displayed		
-		A56	REV NO	Revision no.	Displays the revision number of firmware running on a microprocessor built in the SDAU.	Always displayed		
-		A58	MENU REV	Menu rev.	Displays the revision of a group of parameters displayed on the JHT200 Handy Terminal.	Always displayed		
-		A60	SELF CHK	Self-diagnostic result	Displays the result of self-diagnosis as "GOOD" or "ERROR."	Always displayed		

JHT200 Handy Terminal					
Symbol Appearing on Digital Display	No.	Display	Item	Description	Display Condition
	B	DISPLAY2	Display 2		
-	B01	INPUT1	Details are the same as for those of the equivalent item in A. The display is periodically updated on the JHT200 Handy Terminal.		
-	B02	INPUT2			
PV1	B03	PV1			
PV2	B04	PV2			
DV	B05	DV			
PV1.VL	B06	PV1.VL			
PV2.VL	B07	PV2.VL			
ALM1	B19	ALM1			
ALM2	B20	ALM2			
ALM3	B21	ALM3			
ALM4	B22	ALM4			
-	B60	SELF CHK			

JHT200 Handy Terminal								
Symbol Appearing on Digital Display	No.	Display	Item	Description	Setting Range	Initial Value	Display Condition	
	F	SET(I/O)	Setting (I/O)					
-	F01	TAG NO.1	Tag no. 1	Eight alphanumeric characters can be entered.	-	-	Always displayed	
-	F02	TAG NO.2	Tag no. 2	Eight alphanumeric characters can be entered.	-	-	Always displayed	
-	F03	COMMENT1	Comment 1	Eight alphanumeric characters can be entered.	-	-	Always displayed	
-	F04	COMMENT2	Comment 2	Eight alphanumeric characters can be entered.	-	-	Always displayed	
F1	F05	FILTER1	See Display on Front Panel: List of Parameters.		See Display on Front Panel: List of Parameters.	See Display on Front Panel: List of Parameters.	Always displayed	
SNSR1	F06	SENSOR TYPE1					- TC - mV - RTD	Displayed on SDAU-270
SQR1	F07	SQR1					- OFF - SQR	Input 1 = 1-5 V
L.CUT1	F08	LOW CUT1					- OFF - ON	SQR1 = SQR when input 1 = 1-5 V
TC TP1	F09	TC TYPE1					- TYPE K - TYPE E - TYPE J - TYPE T - TYPE R - TYPE S - TYPE B - TYPE N - TYPE W3 - TYPE W5	SENSOR TYPE1 = TC for SDAU-270

JHT200 Handy Terminal							
Symbol Appearing on Digital Display							
Symbol	No.	Display	Item	Description	Setting Range	Initial Value	Display Condition
RT TP1	F10	RTD TYPE1	See Display on Front Panel: List of Parameters.		- Pt100-90 (ITS-90, JIS'97) - Pt100-68 (IPTS-68, JIS'89) - JPt100 (JIS'89) - Pt50 (JIS'81)	See Display on Front Panel: List of Parameters.	SENSOR TYPE1 = RTD for SDAU-270
UNIT	F11	UNIT1			- degC - K - degF		
RH1	F12	RH1	See Display on Front Panel: List of Parameters.				Input 1 is any input other than 1-5 V.
RL1	F13	RL1					
DP1	F14	DP1	See Display on Front Panel: List of Parameters.	- ##### - #####.# - ###.### - ##.###	See Display on Front Panel: List of Parameters.	Input 1 is 1-5 V or mV input.	
SCH1	F15	SCH1	See Display on Front Panel: List of Parameters.				Input 1 is 1-5 V or mV input.
SCL1	F16	SCL1					Input 1 is 1-5 V or mV input.
RJC	F17	RJC	See Display on Front Panel: List of Parameters.	- ON - OFF	See Display on Front Panel: List of Parameters.	Input 1 or input 2 is TC input.	
R.CONST	F18	RJC CONST	See Display on Front Panel: List of Parameters.				RJC=OFF
-	F19	BURN OUT1	Burnout 1	Specifies the action to be taken in the event of burnout of input 1. Note: Be aware if this parameter is changed, details are different from those of auxiliary codes on the nameplate.	- OFF (no specification) - UP (/BU) - DOWN (/BD)	OFF (An item to be specified when ordering)	Input 1 is any input other than 1-5 V.
PV1	F20	PV1	See Display on Front Panel: List of Parameters.				Always displayed
BIAS1	F21	BIAS1					
F2	F22	FILTER2					
SNSR2	F23	SENSOR TYPE2	See Display on Front Panel: List of Parameters.	See SENSOR TYPE1.	See Display on Front Panel: List of Parameters.	SDAU-270	
SQR2	F24	SQR2	See SQR1.	See SQR1.			Input2 = 1-5V
L.CUT2	F25	LOW CUT2	See LOW CUT1.	See LOW CUT1.			SQR2 = SQR when Input 2 = 1-5 V
TC TP2	F26	TC TYPE2	See TC TYPE1.	See TC TYPE1.			SENSOR TYPE2 = TC for SDAU-270
RT TP2	F27	RTD TYPE2	See RTD TYPE1.	See RTD TYPE1.			SENSOR TYPE2 = RTD for SDAU-270
UNIT2	F28	UNIT2	See UNIT1.	See UNIT1.			Input 2 is temperature input.

JHT200 Handy Terminal							
Symbol Appearing on Digital Display Symbol	No.	Display	Item	Description	Setting Range	Initial Value	Display Condition
RH2	F29	RH2	See Display on Front Panel: List of Parameters.				Input 2 is any input other than 1-5 V.
RL2	F30	RL2					
DP2	F31	DP2	See Display on Front Panel: List of Parameters.		See DP1.	See Display on Front Panel: List of Parameters.	Input 2 is 1-5 V or mV input.
SCH2	F32	SCH2	See Display on Front Panel: List of Parameters.				Input 2 is 1-5 V or mV input.
SCL2	F33	SCL2					
-	F34	BURN OUT2	Burnout 2	Specifies the action to be taken in the even of burnout of input 2. (Details are the same as those for input-1 type.)	See Display on Front Panel: List of Parameters.		Input 2 is any input other than 1-5 V.
PV2	F35	PV2	See Display on Front Panel: List of Parameters.				Always displayed
BIAS2	F36	BIAS2					Always displayed
SKIP	F37	SKIP	See Display on Front Panel: List of Parameters.		- NO - YES	See Display on Front Panel: List of Parameters.	Always displayed
H/C	F38	HOT/COLD			- COLD - HOT		Always displayed
DSPM	F39	DSP MODE			- OFF - ON		Always displayed
FAIL.M	F40	FAIL MODE			- ON - OFF		For options other than /RLY4, /VLT, and /CUR
-	F60	SELF CHK	Self-diagnostic result	Displays the self-diagnostic result.	Displays "GOOD" or "ERROR."	-	Always displayed

JHT200 Handy Terminal								
Symbol Appearing on Digital Display	Symbol	No.	Display	Item	Description	Setting Range	Initial Value	Display Condition
		G	SET (ALM)	Setting (alarm)				
TM.M	G01	TIMER MODE			See Display on Front Panel: List of Parameters.	- DELAY.T - ON.OFF.T	See Display on Front Panel: List of Parameters.	Always displayed
AL1_H	G02	AL1_H				- 000 - 001 - 010 - 011 - 100 - 101 - 110 - 111		Always displayed
AL1_L	G03	AL1_L				See AL1_H.		Always displayed
AN.OR.1	G04	AND.OR.1				- OR - AND		Always displayed
ACT1	G05	RLY1 ACTION				- NRM DE-ENERGIZED (De-energized) - NRM ENERGIZED (Energized)		Always displayed
TM1	G06	DELAY TIM1			See Display on Front Panel: List of Parameters.			TIMER MODE = DELAY.T

JHT200 Handy Terminal							
Symbol Appearing on Digital Display Symbol	No.	Display	Item	Description	Setting Range	Initial Value	Display Condition
ON.TM1	G07	ON DELAY1	See Display on Front Panel : List of Parameters				TIMER MODE = ON.OFF.T
OF.TM1	G08	OFF DELAY1	See Display on Front Panel : List of Parameters				TIMER MODE = ON.OFF.T
AL2_H	G09	AL2_H	See Display on Front Panel: List of Parameters.	See AL1_H.	See AL1_H.	See Display on Front Panel: List of Parameters.	Always displayed
AL2_L	G10	AL2_L		See AL1_H.			Always displayed
AN.OR.2	G11	AND.OR. 2		See AND.OR.1.			Always displayed
ACT2	G12	RLY2 ACTION		See RLY1 ACTION.			Always displayed
TM2	G13	DELAY TIM2	See Display on Front Panel: List of Parameters.				TIMER MODE = DELAY.T
ON.TM2	G14	ON DELAY2	See Display on Front Panel: List of Parameters.				TIMER MODE = ON.OFF.T
OF.TM2	G15	OFF DELAY2	See Display on Front Panel: List of Parameters.				TIMER MODE = ON.OFF.T
AL3_H	G16	AL3_H	See Display on Front Panel: List of Parameters.	See AL1_H.	See AL1_H.	See Display on Front Panel: List of Parameters.	/RLY4
AL3_L	G17	AL3_L		See AL1_H.			/RLY4
AN.OR.3	G18	AND.OR. 3		See AND.OR.1.			/RLY4
ACT3	G19	RLY3 ACTION		See RLY1 ACTION.			/RLY4
TM3	G20	DELAY TIM3	See Display on Front Panel: List of Parameters.				TIMER MODE = DELAY.T for /RLY4
ON.TM3	G21	ON DELAY3	See Display on Front Panel: List of Parameters.				TIMER MODE = ON.OFF.T for /RLY4
OF.TM3	G22	OFF DELAY3	See Display on Front Panel: List of Parameters.				TIMER MODE = ON.OFF.T for /RLY4
AL4_H	G23	AL4_H	See Display on Front Panel: List of Parameters.	See AL1_H.	See AL1_H.	See Display on Front Panel: List of Parameters.	/RLY4
AL4_L	G24	AL4_L		See AL1_H.			/RLY4
AN.OR.4	G25	AND.OR. 4		See AND.OR.1.			/RLY4
ACT4	G26	RLY4 ACTION		See RLY1 ACTION.			/RLY4
TM4	G27	DELAY TIM4	See Display on Front Panel: List of Parameters.				TIMER MODE = DELAY.T for /RLY4
ON.TM4	G28	ON DELAY4	See Display on Front Panel: List of Parameters.				TIMER MODE = ON.OFF.T for /RLY4
OF.TM4	G29	OFF DELAY4	See Display on Front Panel: List of Parameters.				TIMER MODE = ON.OFF.T for /RLY4

JHT200 Handy Terminal							
Symbol Appearing on Digital Display Symbol	No.	Display	Item	Description	Setting Range	Initial Value	Display Condition
MOD1	G30	MOD1		See Display on Front Panel: List of Parameters.	- PV1 - PV2 - PV1 - PV2 - PV1.VL - PV2.VL	See Display on Front Panel: List of Parameters.	Always displayed
HYS1	G31	HYSTER ESIS1		See Display on Front Panel: List of Parameters.			MOD1 is input other than a PVn rate-of-change alarm.
VL1.TM	G32	VL1 TIMER		See Display on Front Panel: List of Parameters.			MOD1 is input other than a PVn rate-of-change alarm.
MOD2	G33	MOD2		See Display on Front Panel: List of Parameters.	See MOD1.	See Display on Front Panel: List of Parameters.	Always displayed
HYS2	G34	HYSTER ESIS2		See Display on Front Panel: List of Parameters.			MOD2 is input other than a PVn rate-of-change alarm.
VL2.TM	G35	VL2 TIMER		See Display on Front Panel: List of Parameters.			MOD2 is input other than a PVn rate-of-change alarm.
MOD3	G36	MOD3		See Display on Front Panel: List of Parameters.	See MOD1.	See Display on Front Panel: List of Parameters.	Always displayed
HYS3	G37	HYSTER ESIS3		See Display on Front Panel: List of Parameters.			MOD3 is input other than a PVn rate-of-change alarm.
VL3.TM	G38	VL3 TIMER		See Display on Front Panel: List of Parameters.			MOD3 is a PVn rate-of-change alarm.
-	G60	SELF CHK	Self-diagnostic result	Displays the self-diagnostic result.	Displays "GOOD" or "ERROR."	-	Always displayed

JHT200 Handy Terminal							
Symbol Appearing on Digital Display Symbol	No.	Display	Item	Description	Setting Range	Initial Value	Display Condition
	H	SET (ALM H/L)	Setting (alarm)				
1H	H01	1H	See Display on Front Panel: List of Parameters.				When 1H is connected to one of AL1_H, AL2_H, AL3_H, or AL4_H.
1L	H02	1L					When 1L is connected to one of AL1_L, AL2_L, AL3_L, or AL4_L.
2H	H03	2H					When 2H is connected to one of AL1_H, AL2_H, AL3_H, or AL4_H.
2L	H04	2L					When 2L is connected to one of AL1_L, AL2_L, AL3_L, or AL4_L.
3H	H05	3H					When 3H is connected to one of AL1_H, AL2_H, AL3_H, or AL4_H.
3L	H06	3L					When 3L is connected to one of AL1_L, AL2_L, AL3_L, or AL4_L.
-	H60	SELF CHK	Self-diagnostic result	Displays the self-diagnostic result.	Displays "GOOD" or "ERROR."	-	Always displayed
	J	SET (RET)					
RET	J01	RET	See Display on Front Panel: List of Parameters.	- OFF - PV1 - PV2 - PV1 - PV2	See Display on Front Panel: List of Parameters.	/VLT or /CUR	
RTH	J02	RTH	See Display on Front Panel: List of Parameters.				Cases other than RET = NONE for /VLT or /CUR
RTL	J03	RTL					Cases other than RET = NONE for /VLT or /CUR
-	J60	SELF CHK	Self-diagnostic result	Displays the self-diagnostic result.	Displays "GOOD" or "ERROR."	-	Always displayed

JHT200 Handy Terminal							
Symbol Appearing on Digital Display Symbol	No.	Display	Item	Description	Setting Range	Initial Value	Display Condition
	K	SET (COM)	Setting (RS-485)				
PSL	K01	PROTOCOL	See Display on Front Panel: List of Parameters.		- PC LINK - PC LINK WITH SUM - LADDER - MODBUS ASCII - MODBUS RTU	See Display on Front Panel: List of Parameters.	/COM
BPS	K02	BAUD RATE			- 1200 bps - 2400 bps - 4800 bps - 9600 bps		/COM
PRI	K03	PARITY			- NONE - EVEN - ODD		/COM
STP	K04	STOP BIT			- 1 bit - 2 bits		/COM
DLN	K05	DATA LEN			Choices: - 7 bits - 8 bits		/COM
ADR	K06	ADDRESS			-		/COM
COMMU	K07	COMMU			- ENABLE - DISABLE		/COM
-	K60	SELF CHK	Self-diagnostic result	Displays the self-diagnostic result.	Displays "GOOD" or "ERROR."	-	Always displayed
	P	ADJUST	Adjustment				
WNGR1	P01	WIRING R1	See Display on Front Panel: List of Parameters.		- RESET - EXECUTE	See Display on Front Panel: List of Parameters.	Input 1 is any input other than 1-5 V.
WNGR2	P02	WIRING R2			- RESET - EXECUTE		Input 2 is any input other than 1-5 V.
-	P03	ZERO ADJ1	Input-1 zero correction	Adjusts the zero point of input 1. Follow this adjustment procedure if it is difficult to adjust with CALn.Z. *1	Choices: - **RST - **INC - **HINC - **HDEC - **DEC ** means mV for mV or TC input, or Ω for RTD input.	-	Always displayed
-	P04	SPAN ADJ1	Input-1 span correction	Adjusts the span of input 1. Follow this adjustment procedure if it is difficult to adjust with CALn.S. *1	See ZERO ADJ1.	-	Always displayed
-	P05	ZERO ADJ2	Input-2 zero correction	Adjust the zero point of input 2. *2	See ZERO ADJ1.	-	Always displayed
-	P06	SPAN ADJ2	Input-2 span correction	Adjust the span of input 2. *2	See ZERO ADJ1.	-	Always displayed

*1: It is initialized if SENSOR TYPE1, TC TYPE1, or RTD TYPE1 changes.

*2: It is initialized if SENSOR TYPE2, TC TYPE2, or RTD TYPE2 changes.

JHT200 Handy Terminal								
Symbol Appearing on Digital Display	Symbol	No.	Display	Item	Description	Setting Range	Initial Value	Display Condition
-		P13	OUT1 0%	Output-1 0% correction	Adjust 0% of retransmission output.	-20.00 to 20.00% *1	-	/VLT or /CUR
-		P14	OUT1 100%	Output-1 100% correction	Adjust 100% of retransmission output.	-20.00 to 20.00% *1	-	/VLT or /CUR
-		P60	SELF CHK	Self-diagnostic result	Displays the self-diagnostic result.	Displays "GOOD" or "ERROR."	-	Always displayed
		Q	TEST	Test				
-		Q02	OUT1 TEST	Output-1 forced output	Forces a set value to be output regardless of the input status.	-25.0 to 125.0% *1	-	/VLT or /CUR
-		Q04	RLY1 TEST	Relay-1 forced output	Forces a relay state to be output regardless of the input status.	- DE-ENERGIZE D (De-energized) - ENERGIZE D (Energized) *1	-	Always displayed
-		Q05	RLY2 TEST	Relay-2 forced output			-	Always displayed
-		Q06	RLY3 TEST	Relay-3 forced output			-	/RLY4
-		Q07	RLY4 TEST	Relay-4 forced output			-	/RLY4
-		Q60	SELF CHK	Self-diagnostic result	Displays self-diagnostic result.	Displays "GOOD" or "ERROR."	-	Always displayed

*1: After completing adjustment and test, press the [OK] key to cancel forced output status. This causes the SDAU to return to normal operation status.

Blank Page

7. MAINTENANCE

This chapter describes the simple maintenance procedures and fuse replacements that can be done in the instrument room or service shop.

7.1 Test Equipments

For efficient maintenance of this alarm unit, it is recommended that the user have the following test equipment manufactured by Yokogawa or their equivalent.

Device	Model Name	Number of Units	Remarks
DC voltage/current standard	7651	1 each	Required for mV DC and thermocouple input type equipment
Decade resistance boxes	2793-01	1	Required for RTD input type equipment
Digital voltmeter	7562	1	
Handy Terminal	JHT200 (BT200)	1	
Cold junction bottle	TMJ	1	Only when necessary
Modular jack conversion adapter	Part No. E9786WH	1	
Analog tester	Type 2415	1	

7.2 Reference Table of Thermocouple and RTD

This instrument has been adjusted in accordance with the JIS thermoelectromotive force table and the resistance ratio table amended in 1995.

For the input signals used to adjust the instruments, refer to JIS C 1602-1995 for the thermocouple input type and to JIS C 1604-1997 for the platinum resistance temperature detector (RTD) input type.

7.3 Adjustment and Check



NOTE

- For details of operation and adjusting procedures of JHT200 Handy Terminal, refer to the instruction manual "JHT200 Handy Terminal" (IM JF81-02E).
- Do not turn off the power of the instrument during adjustment.

7.3.1 Input Adjustment

Adjustment using key switches

This adjustment uses the CALn.Z and CALn.S parameters (for the case of 1-5 V input only).

Connect devices as shown in the figure below, turn on the power of each device, and warm up the devices for approx. 5 minutes. Then carry out the adjustments.

For how to make the adjustments, see Adjustment-related Parameters of Section 6.3, "Display on Front Panel: List of Parameters."

Adjustments via the JHT200 Handy Terminal

The adjustment parameters are as follows:

Parameters P3 and P4: Zero and span adjustments of input 1

Parameters P5 and P6: Zero and span adjustments of input 2

Use JHT200 Handy Terminal for adjustment.

The procedure for adjustment is describes below.

- (a) Connect the test equipment corresponding to each of input referring to Figure 7.1 through Figure 7.3.
- (b) For thermocouple input, set reference junction compensation to OFF temporarily.
- (c) Set the parameter write protect (W.P.) of setting jumper to OFF.
- (d) Turn on the power while the equipment is connected to the instrument, and allow a warm-up period of about 5 minutes.
- (e) Connect JHT200 Handy Terminal.
- (f) Call P03: ZERO ADJ1 of the adjustment item (P: ADJUST).
- (g) Apply an input equivalent to 0% of the input range. Check the input value and the input display value of P03: ZERO ADJ1.
- (h) If the input value does not correspond to the display value of P03, adjust it using P03 parameter.
- (i) Select INC (addition) or DEC (subtraction) for adjustment. (Selecting RST resets the adjusted value and retrieves the factory-set default.) When the error is large, select HINC or HDEC for adjustment using a value ten times as large as INC or DEC.
- (j) Perform the same procedure for the 100% of input range. Use the parameter P04: SPAN ADJ1.
- (k) After completing the adjustment, set the parameter write protect (W.P.) of setting jumper to ON as necessary.
- (l) For thermocouple input, set the reference junction compensation to ON.

* Above the same procedure for the adjustment of input 2, using parameters P05: ZERO ADJ2 and P06: SPAN ADJ2.

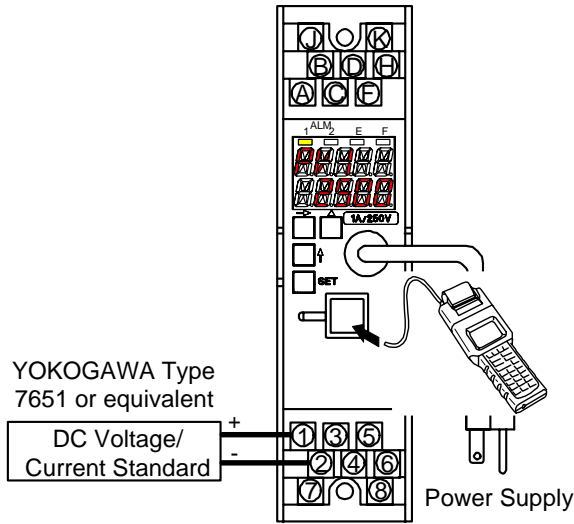

Figure 7.1 Wiring for mV DC Input Adjustment

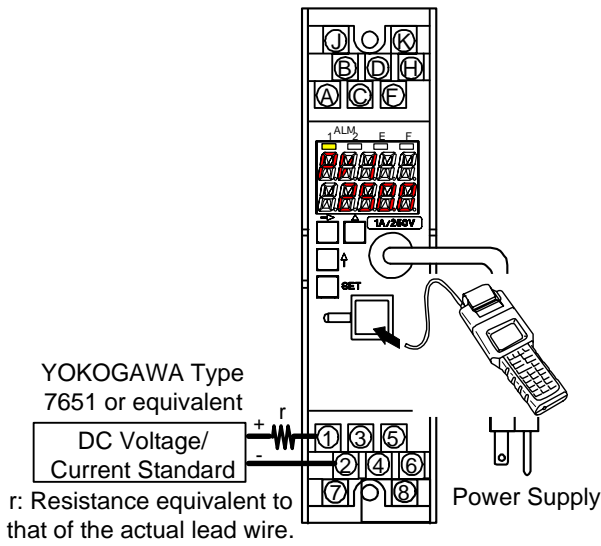

Figure 7.2 Wiring for Termocouple Input Adjustment

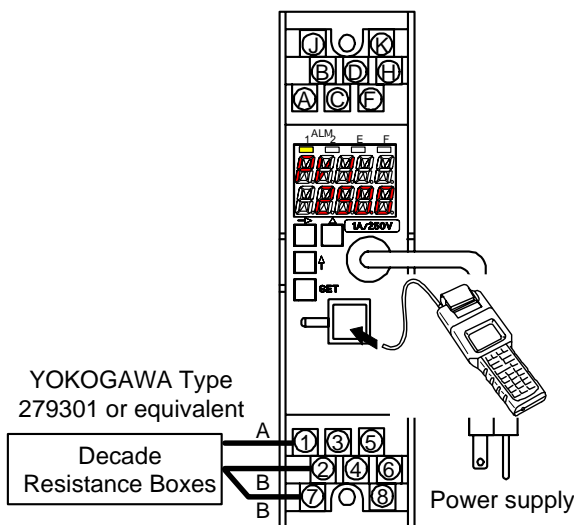

Figure 7.3 Wiring for RTD Input Adjustment

7.3.2 Correction of Input Wiring Resistance

If an error occurs because of input wiring resistance when mV DC, thermocouple or RTD input, or if using a safety barrier such as BARD and the like with the instrument, input wiring resistance can be corrected by parameter using JHT200 Handy Terminal.



NOTE

Correction of input wiring resistance should be made after completion of mounting wiring.

To correct input wiring resistance, use the front display parameter WNGR1 or WNGR2 or the JHT200 Handy Terminal.

The following describes how to correct the wiring resistance of input 1, using the JHT200 Handy Terminal.

For details, refer to "Correction of wiring Resistance using the JHT200" of the instruction manual "JHT200 Handy Terminal" (IMJF81-02E)

- (a) Set the parameter write protect (W.P.) of setting jumper to OFF.
- (b) Short-circuit the wires for input of the instrument on the sensor side.
Short-circuit the 2 wires for mV DC or thermocouple input.
Short-circuit the 3 wires for RTD input.
- (c) Connect JHT200 Handy Terminal. (Refer to Figure for Wiring.)
- (d) Call P01: WIRING R1 of adjustment items (P: ADJUST).
- (e) Select <EXECUTE>, and press ENTER twice.
- (f) After the correction, set the parameter write protect (W.P.) of setting jumper to ON.

* Above the same procedure for the correction of the wiring resistance of input 2, using P02: WIRING R2 parameter.

To correct input 1 wiring resistance using a front display parameter, first follow steps (a) and (b) above, then set WNGR1 to 1.

Correct input 2 wiring resistance as instructed above, using WNGR2.

● Precautions when connecting the BARD safety barrier to an alarm unit with an RTD input



NOTE

To minimize errors due to the effect of BARD's internal resistance, connect the alarm unit as shown on the next page. (The connection method is different for this style-R SDAU alarm unit and the style-E SDAU alarm unit.)

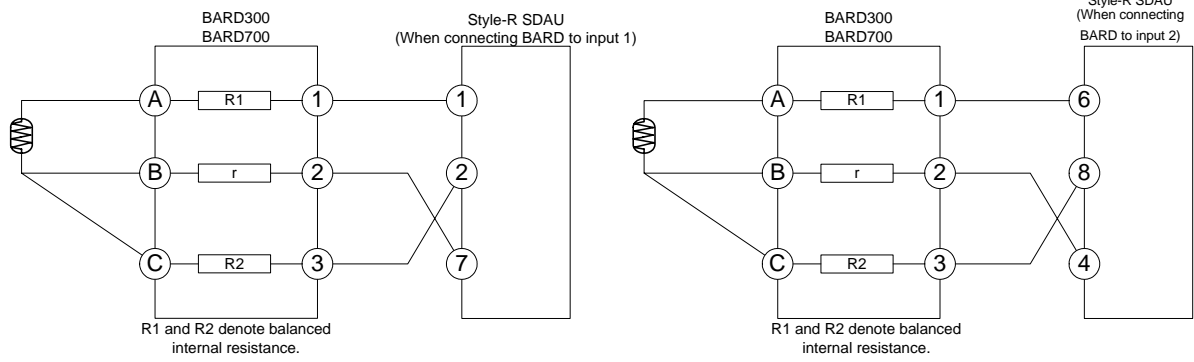

Figure 7.4 Connection between BARD and an Alarm Unit with RTD Input

7.5 Replacement of Fuse

When the fuse has blown or requires replacement, replace it according to the following procedure. Recommended replacement interval is about three years.

Before replacing a fuse, turn off the power to the instrument.



NOTE

- When a fuse has blown, check for the cause first because a fuse itself may not be responsible for the problem. Then replace the fuse.
- Use the dedicated fuse (S9510VK). Do not use a fuse for other products.

- (1) Remove the fuse holder cap, then pull the fuse out in the direction shown in Figure 7.6.
- (2) When installing a new fuse, use a fuse with the correct rating. Fasten the cap securely.

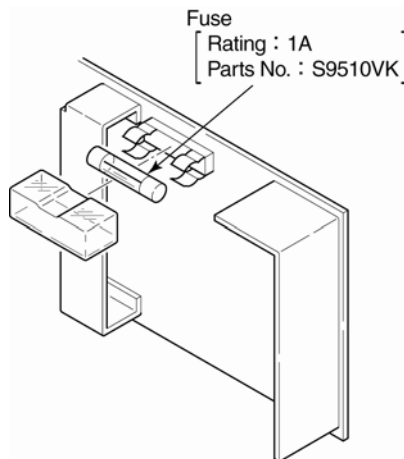

Figure 7.6 Replacement of Fuse

7.6 Replacement of Capacitor

Degradation of the aluminum electrolytic capacitor used in the power supply unit depends on operating temperature condition or operating environment. Recommended replacement interval is five to ten years.



NOTE

- Ask your nearest Yokogawa sales staff to replace the capacitor.
 - Do not replace the capacitor by yourself, because the part numbers of power supply unit (refer to CMPL 01B04K03-02E) and capacitor to be used are different according to the power supply specifications.
-

7.7 Replacement of Relays

The relays used for alarm action are influenced and deteriorate according to the connected load and number of ON/OFF switching operations. We recommend replacing relays at the following replacement cycle:

600,000 ON/OFF switching operations with rated load connected
(equivalent to 10 years with one operation every 10 minutes)



NOTE

- Ask your nearest Yokogawa sales staff to replace relays.
 - Do not replace relays by yourself.
-

8. TROUBLESHOOTING

If any fault occurs in the instrument, note down the symptoms, and follow Section 8.1 Troubleshooting Flowchart.

To find the fault, first wire the instruments according to the maintenance wiring diagram, apply an input signal, and note down the symptoms.

If the fault also requires replacement of the power supply unit, main board or display, or is difficult to find, contact your nearest Yokogawa Service Center.

8.1 Troubleshooting Flow

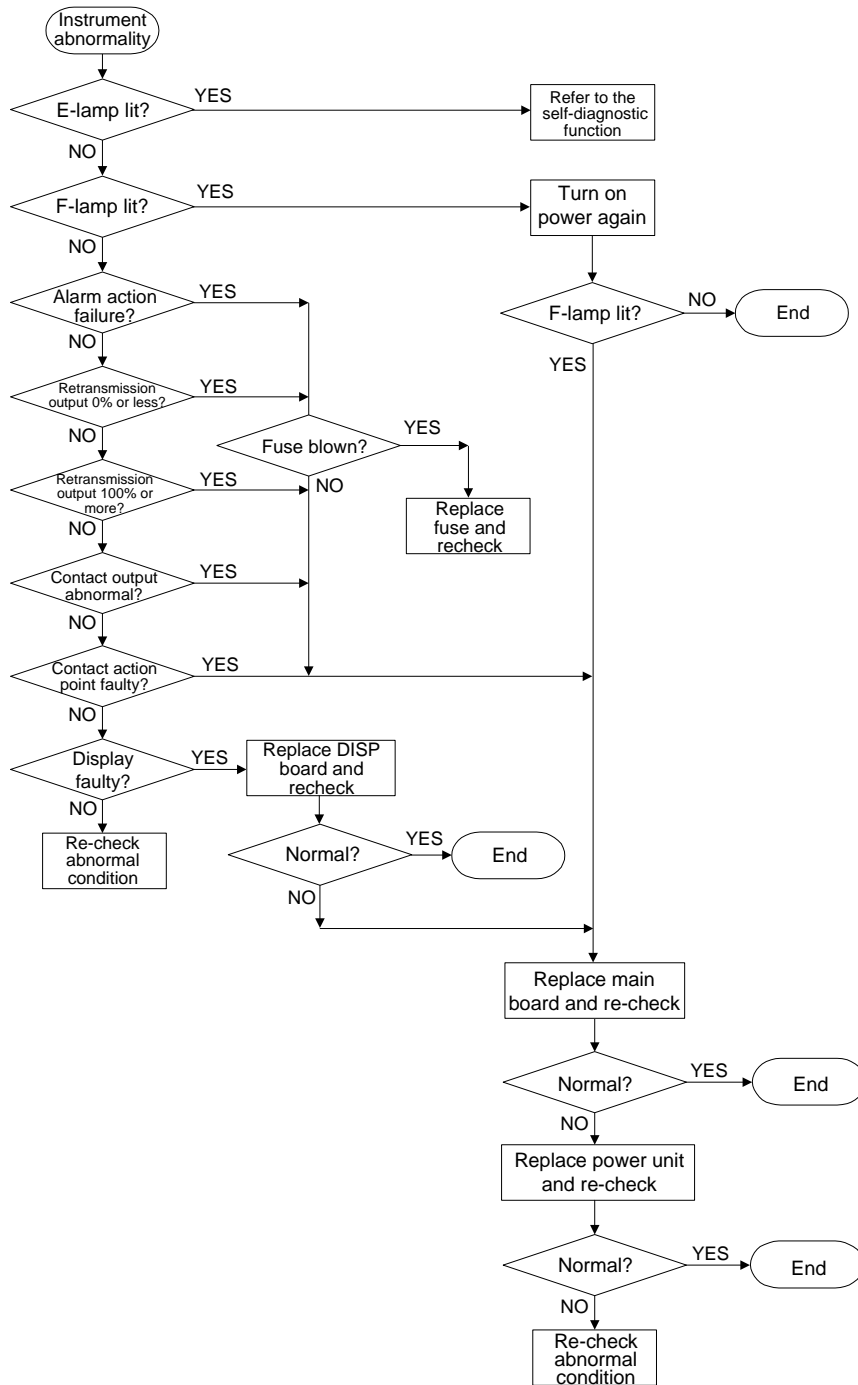

Figure 8.1 Troubleshooting Flow

8.2 Actions under Fault Conditions

The SDAU has a self-diagnostic function capable of detecting an error/failure in the instrument itself. If detecting any abnormality, the SDAU makes notification by the following means: an error indication appears in the lower half of the digital display, a parameter (FLAG) is displayed in the upper half of it, a lamp on the front panel is lit, the failure output contact (when the /RLY4, /CUR, or /VLT option is not specified) is de-energized, and/or an alarm output contact is activated.

FLAG	Digital Display		Display on Handy Terminal		Cause of Error	Operation	Cause	Remedy
	Indication in the event of error *2	Display of self-diagnostic result *3	SELF CHECK	Detailed Error Info *4				
					CPU failure: Internal WDT	Lamp lit: F lamp Alarm output contacts: All de-energized Failure output contact: De-energized. Key switches: Disabled Communication: Stopped Retransmission output: 0 V or 0 mA	WDT error	Replace the main board.
					CPU failure: External WDT, ROM failure, RAM failure	Lamp lit: F-lamp Alarm output contacts: All de-energized Failure output contact: De-energized. Key switches: Disabled Communication: Stopped Retransmission output: 0 V or 0 mA	Hardware (such as microprocessor, clock) failure	
					Power failure	State identical to power OFF Lamps: All OFF Alarm output contacts: All de-energized Failure output contact: De-energized. Key switches: Disabled Communication: Stopped Retransmission output: 0V or 0mA	Power abnormality Blown fuse	Replace the main board and/or fuse.

FLAG	Digital Display		Display on Handy Terminal		Cause of Error	Operation	Cause	Remedy
	*1 Indication in the event of error *2	Display of self-diagnostic result *3	SELF CHECK	Detailed Error Info *4				
					Display board failure	Lamp lit: All OFF Failure output contact: Energized, and alarm detection and alarm output action continue. Key switches: Disabled Communication: Normal Retransmission output: Normal action	Faulty display board	Replace the display board.
0004	<i>AD.ER</i> AD.ER flashing *5		ERROR	AD ERROR	A/D conversion failure	Lamp lit: F-lamp Alarm output contacts: All de-energized Failure output contact: De-energized.	Faulty A/D converter	Replace the main board.
0100	<i>EEP.ER</i> EEP.ER flashing *5		ERROR	EEPROM ERROR	EEPROM failure	Key switches: Disabled Communication: • RS-485 communication: Stopped • BRAIN communin: Undefined (there are cases where communication is disabled) Retransmission output: 0 V or 0 mA	Faulty EEPROM (read/write)	
0080	<i>SU.ER</i> SU.ER flashing *5		ERROR	EEPROM SUM ERROR	EEPROM SUM failure		EEPROM SUM failure	
8000	<i>RJC.ER</i> RJC.ER flashing *5		ERROR	RJC ERROR	RJC failure		Abnormal RJC sensor or the terminal temperature is beyond the range of -20 to 80°C (*6)	

FLAG	Digital Display		Display on Handy Terminal		Cause of Error	Operation	Cause	Remedy
	Indication in the case of error *2	Display of self-diagnostic result *3	SELF CHECK	Detailed Error Info.* 4				
0800	<i>1boUt</i> 1.BOUT	<i>1boUt</i> 1.BOUT	ERROR	INPUT1 BURN OUT	Input-1 burnout	Lamp lit: E-lamp Failure output contact: Refer to Note 8 (*8), but alarm detection and alarm output action continue. Key switches: All enabled Communi- cations: Normal Retransmission output: Normal action	When A/D conversion count value is at high and low limit, and the input mode and output connections are set so that the input is related to the occurrence of alarm output. (*7)	Connect input 1 or 2 correctly.
1000	<i>2boUt</i> 2.BOUT	<i>2boUt</i> 2.BOUT	ERROR	INPUT2 BURN OUT	Input-2 burnout			
0001		<i>1oV ER</i> 1.OVER	ERROR	INPUT1 OVER	Input-1 overrange	When input is more than 106.25% or less than -6.25% of RH and RL, and the input mode and output connections are set so that the input is related to the occurrence of alarm output.	Put input 1 or 2 into the range.	
0002		<i>2oV ER</i> 2.OVER	ERROR	INPUT2 OVER	Input-2 overrange			

FLAG	Digital Display		Display on Handy Terminal		Cause of Error	Operation	Cause	Remedy
	*1 Indication in the case of error *2	Display of self-diagnostic result *3	SELF CHECK	Detailed Error Info.* 4				
0040	<i>HotEr</i> HOT.ER	<i>HotEr</i> HOT.ER	ERROR	HOT START ERROR	HOT start disabled	Lamp lit: E-lamp Failure output contact: Refer to Note 8 (*8), but alarm detection and alarm output action continue. Key switches: All enabled Communications: Normal Retransmission output: Normal action In case of FLAG 0040, COLD start applies.	Only when HOT start mode is set, a HOT start data error, or a power failure during a write to EEPROM	Turn on power again (for HOT.ER only) or press the SET switch with parameter FLAG displayed on the digital display on front panel. (*9)

- *1: If multiple FLAG codes have occurred, a value obtained by adding codes as hexadecimal numbers is displayed.
- *2: The upper half of the digital display indicates a PV parameter (PVn, DV, PVn, or VL), while the lower half shows the relevant error description.
If multiple errors occur, an error with the highest display priority will be displayed. Display priority is given such that the top row in the table above has the highest priority.
- *3: Pressing the [→] key with a FLAG parameter displayed allows an error description to be displayed in the upper half of the digital display.
In this case, the lower half of the display shows no data.
- *4: This information is displayed when the SELF CHK function is called up.
- *5: This indication also appears if an item other than PV is disabled. It appears in the upper half of the digital display.
- *6: Compensation is made by limited reference junction temperature (-20°C or 80°C).
- *7: For the JHT200 Handy Terminal, enter "0000" in A53 FLAG or turn on the power again (error can be cleared in case of HOT.ER only).
- *6: When the RJC parameter is set to OFF and neither input 1 nor input 2 is an TC input, the alarm unit does not detect any RJC failure.
- *7: When the Burnout parameter is set to OFF, the alarm unit does not detect any burnout failure.
- *8: The action of the failure output contact depends on the setting of the F40 "FAIL MODE (FAIL.M)" parameter. (See Section 4.7, "Self-Diagnostic Function," for more information.)
- *9: For the JHT200 Handy Terminal, enter "0000" in A53 FLAG or turn on the power again.

8.3 Replacement of Parts



WARNING

Replacement of parts must be performed by trained service personnel with the required electrical knowledge and skills. If customer service personnel are to replace parts, first thoroughly read this user's manual to familiarize yourself with the procedure.

8.3.1 Replacement Procedure

The following replacement procedures are described:

- Replacement of Power Supply Unit
- Replacement of Internal Unit
- Replacement of Display



NOTE

When replacing a part, disassemble the instrument as little as possible and carry out the disassembly carefully.

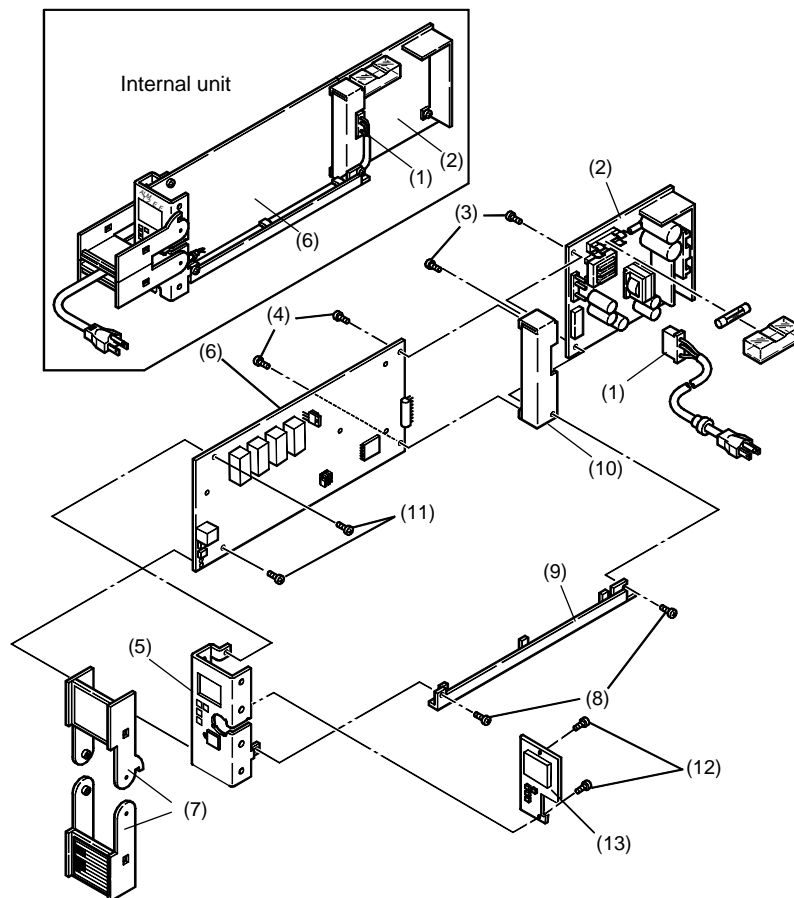

Figure 8.2 Disassembling the SDAU

8.3.2 Replacement of Power Supply Unit

- (a) Pull the terminal cover (7) toward you to draw out the internal unit from the rack case.
- (b) Unplug the connector (1) from the power supply unit (2).
- (c) Remove two screws (3) to separate the power supply unit (2) from the bracket (10).
- (d) Assemble the new power supply unit following the steps (c) through (a).



NOTE

- Use the power supply unit for style R for replacement (refer to CMPL).
- The power supply unit of former style without compatibility cannot be used.

8.3.3 Replacement of Main Board

- (a) Remove the power supply unit (2).
(Refer to Subsection 8.3.2 for operating procedure.)
- (b) Remove two screws (8) to separate the bracket (9).
- (c) Remove four screws (4) to separate the bracket (10) and the front bracket (5) from the main board (6).
- (d) Assemble the new internal unit following steps (c) through (a).
When adjusting how the connector of the display board (13) is engaged with that of the main board (6), temporarily loosen the two screws (12).

8.3.4 Replacement of Display Board

- (a) Remove the connector (1) from the power supply unit (2).
- (b) Remove two screws (8) to separate the bracket (9).
- (c) Remove two screws (11) to separate the front bracket (5) from the main board (6).
- (d) Remove two screws (12) to separate the display board (13) from the front bracket (5).
- (e) Assemble the new front bracket following steps (d) through (a).
When adjusting how the connector of the display board (13) is engaged with that of the main board (6), temporarily loosen the two screws (12).

Blank Page

Appendix. /TB Power Supply Terminal Connections (Option)

Appendix-1 GENERAL

If you specify the optional terminal block (optional suffix code /TB), the power supply is connected directly to the terminal block. So, drawing out the internal unit requires turning off the power supply and disconnecting the wiring from the terminal block.

Appendix-2 APPLICABLE INSTRUMENTS

Model	Description
STED	mV, Temperature and Potentiometer/Voltage Converters
SKYD	Alarm Unit
SALD	mV and Temperature Alarm Unit
SDAU	Digital Alarm Unit
SPLR	Programmable Computing Unit
SIND	Integrator
SISD	Isolator
SDBT	Distributor (for 1 point)
SDBS	Distributor (for 4 points)
SDBU-21	Distributor (for 1 point)

Appendix-3 NAMES OF COMPONENTS AND POWER TERMINAL SYMBOLS

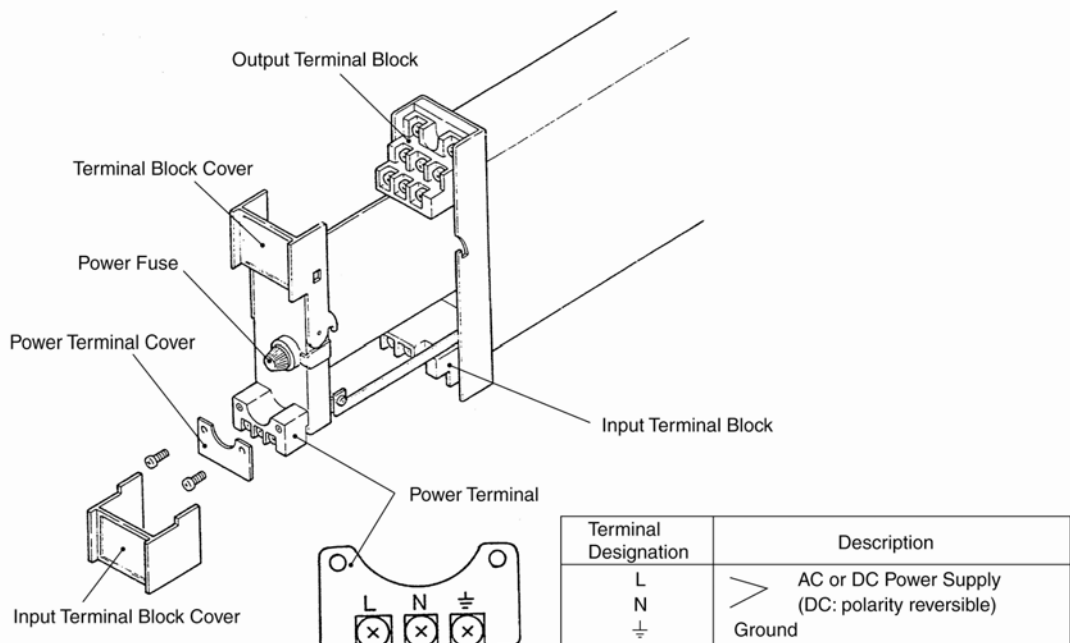

Figure 1 Names of Parts and Power Terminal

Appendix-4 POWER SUPPLY AND GROUND WIRING

(1) All cable ends must be furnished with crimp-on type solderless lugs (for 4 mm screws).

(2) Examples of applicable cables:

Cross-sectional area of the cable conductor: 2.0 mm^2 *

For the power supply, use cable having a cross-sectional area of at least 1.25 mm^2 .

Applicable cable: 600 V PVC insulated cable (IV) stranded wires, conforming to JIS C3307.

PVC insulated cables for electric appliances (KIV) stranded wires, conforming to JIS C3316.

Note *: Power supply cables should be determined from the instrument power consumption. They must have conductors with cross-sectional area of at least 1.25 mm^2 .

(3) Wirings to power supply and ground terminals should be made after completion of signal terminal wirings.

(When signal terminal wirings are made after completion of power supply wiring, pull the internal unit approximately half way out of the housing. Do not remove the power terminal block.)

(4) After completing the power supply and ground wiring, mount the power terminal cover.

Customer Maintenance Parts List

Model SDAU (Style R)
Digital Alarm Unit

YEW SERIES 80

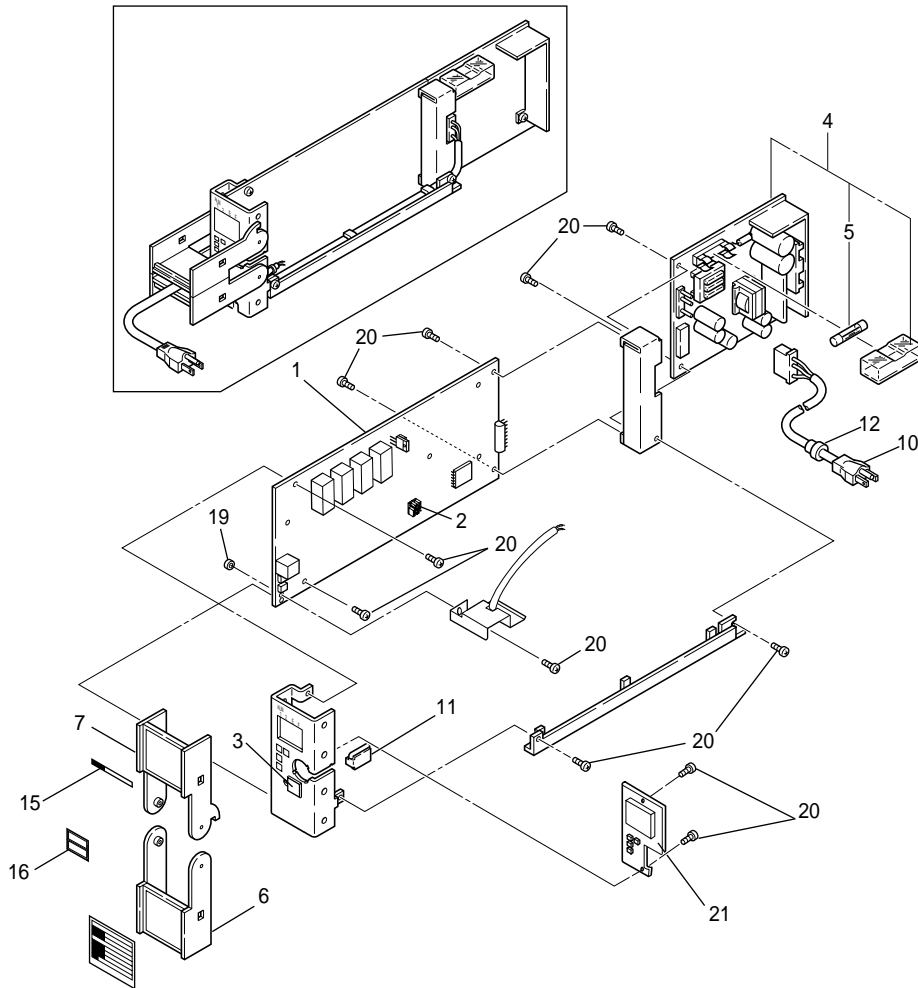

Item	Part No.	Qty							Description	
		Model								
		SDAU-100	SDAU-100/RLY4	SDAU-110,-130	SDAU-120	SDAU-270	SDAU-270/HLT	SDAU-270/CUR	SDAU-270/RLY4	
1	L3040GA	1								Main Board Assembly
	L3040GB		1							Main Board Assembly
	L3040GC			1						Main Board Assembly
	L3040GD				1					Main Board Assembly
	L3040GE					1				Main Board Assembly
	L3040GF						1			Main Board Assembly
	L3040GG							1		Main Board Assembly
	L3040GH								1	Main Board Assembly
2	A1211JS	1	1	1	1	1	1	1	1	Socket & Holder
3	L4040EA	1	1	1	1	1	1	1	1	Cap
4	L3040YB	1	1	1	1	1	1	1	1	Power Supply Unit (for 100V Version)
	L3040YS	1	1	1	1	1	1	1	1	Power Supply Unit (for 220V Version)
5	S9510VK	1	1	1	1	1	1	1	1	Fuse (1A)
6	E9713CA	1	1	1	1	1	1	1	1	Cover
7	E9713CK	1	1	1	1	1	1	1	1	Cover
10	E9713EG	1	1	1	1	1	1	1	1	Cable Assembly(for 100V Version)
	E9713FS	1	1	1	1	1	1	1	1	Cable Assembly(for 220V Version)
11	E9713CE	1	1	1	1	1	1	1	1	Cover
12	S9079PB	1	1	1	1	1	1	1	1	Bushing
15	Y9422NP	1	1	1	1	1	1	1	1	Tag No. Label (blank)
16	L4040JA	1	1	1	1	1	1	1	1	Label (blank)
19	Y9301BB				1	1	1	1	1	Nut
20	Y9306JB	10	10	10	11	11	11	11	11	Pan H. Screw, M3
21	L3040CB	1		1	1	1	1	1	1	Display Board Assembly
	L3040CC	1							1	Display Board Assembly

Note 1: Only for thermocouple input type and universal input type.

Customer Maintenance Parts List

/TB
Power Supply Terminals
For Rack-Mounted Instruments
(Option)

YEW SERIES 80

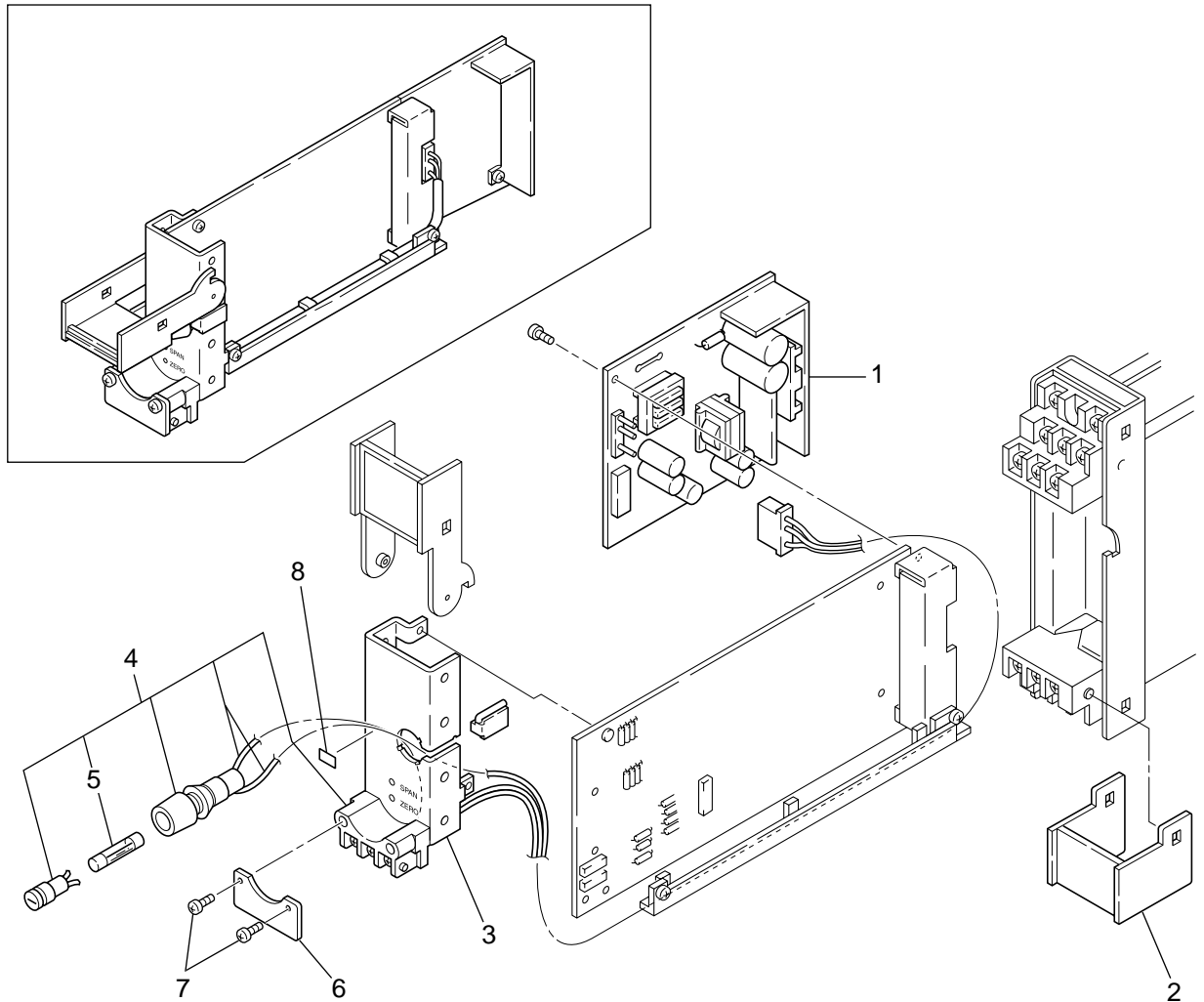

Item	Part No.	Qty	Description
1	—	1	Power Supply Unit (see Table 1)
2	E9713CJ	1	Cover
3	—	1	Bracket (see Table 2)
4	E9713ET	1	Terminal Assembly
5	S9510VK	1	Fuse (1A)
6	E9713CV	1	Cover
7	Y9306JB	2	Pan H. Screw, M3 × 6
8	E9714DM	1	Label (1A/250V)

Table 1. Power Supply Unit Part Number.

Applicable Instruments	Power Supply Unit Part No.	
	100 V Version	200 V Version
SPLR	E9715YH	/
STED, SISD, SDBT	L3040YH	
SALD, SKYD, SIND, SDAU	L3040YJ	
SDBS, SDBU-21	E9715YK	
SPCM	E9715YL	

Table 2. Bracket Part Number.

Applicable Instruments	Bracket Part No.
Model	
STED-110/310/410	L4040CA
STED-210	L4040CB
STED-710	L4040CC
SISD,SIND-100/200, SDBT-21	L4040CE
SKYD-200/201/302	L4040CG
SKYD-100/101,SALD-110/310	L4040CH
SKYD-204/304	L4040CL
SKYD-104	L4040CM
SALD-210/710	L4040CQ
SALD-724	L4040CS
SALD-214/714	L4040CT
SIND-104/204	L4040CX
SDBS	E9713DR
SDBT-11	E9713DL
SDAU-xxx/TB	L4040DA
SDAU-100/RLY4/TB	L4040DB
SDAU-270/RLY4/TB	
SDAU-xxx/TB/COM	L4040DE
SDAU-100/RLY4/TB/COM	L4040DF
SDAU-270/RLY4/TB/COM	

Revision Information

Title : Model SDAU Digital Alarm Unit User's Manual
Manual No. : IM 01B04K03-02E

Mar.31,2004/5th Edition

Style change

May 01,2004/6th Edition

Revised according to the error corrections and change of the company name.

Written by Yokogawa Electric Corporation

Published by Yokogawa Electric Corporation
2-9-32 Nakacho, Musashino-shi, Tokyo 180-8750, Japan

Blank Page

YOKOGAWA

Yokogawa Electric Corporation

YOKOGAWA ELECTRIC CORPORATION

Network Solutions Business Div.

2-9-32, Nakacho, Musashino-shi, Tokyo, 180-8750 JAPAN

Phone: +81-422-52-7179 Facsimile: +81-422-52-6793

Sales Branch Offices

Tokyo, Nagoya, Osaka, Fukuoka

YOKOGAWA CORPORATION OF AMERICA

Headquarters

2 Dart Road, Newnan, GA. 30265-1094 U.S.A.

Phone: +1-770-253-7000 Facsimile: +1-770-251-2088

Sales Branch Offices / Texas, Phoenix, Chicago, Detroit, Los Angeles, New Jersey, Oklahoma

YOKOGAWA EUROPE B. V.

Headquarters

Databankweg 20, Amersfoort 3821 AL THE NETHERLANDS

Phone: +31-334-64-1611 Facsimile: +31-334-64-1610

Sales Branch Offices / Houten (Netherlands), Wien (Austria), Zaventem (Belgium), Ratingen (Germany), Madrid (Spain), Bratislava (Slovakia), Runcorn (United Kingdom), Milano (Italy), Velizy villacoublay(France), Johannesburg(Republic of South Africa)

YOKOGAWA AMERICA DO SUL S.A.

Headquarters & Plant

Praca Acapulco, 31-Santo Amaro, Sao Paulo/SP, CEP-04675-190 BRAZIL

Phone: +55-11-5681-2400 Facsimile: +55-11-5681-1274/4434

YOKOGAWA ENGINEERING ASIA PTE. LTD.

Head office

5 Bedok South Road, 469270 SINGAPORE

Phone: +65-241-9933 Facsimile: +65-241-2606

YOKOGAWA ELECTRIC KOREA CO., LTD.

Head office

395-70, Shindaebang-dong, Dongjak-gu, Seoul, 156-010, KOREA

Phone: +82-2-3284-3021 Facsimile: +82-2-3284-3016

YOKOGAWA TAIWAN CORPORATION

Head office

17F, No.39, Sec. 1, Chung Hwa Road Taipei, 100 TAIWAN

Phone: +886-2-2314-9166 Facsimile: +886-2-2314-9918

YOKOGAWA AUSTRALIA PTY. LTD.

Head office

Centre Court D1, 25-27 Paul Street North, North Ryde, N. S. W. 2113, AUSTRALIA

Phone: +61-2-9805-0699 Facsimile: +61-2-9888-1844

YOKOGAWA BLUE STAR LTD.

Head office

40 / 4 Lavelle Road, Bangalore, 560 001, INDIA

Phone: +91-80-227-1513 Facsimile: +91-80-227-4270

LTD. YOKOGAWA ELECTRIC

Headquarters

Grokholskiy per. 13, Build. 2, 4th Floor, 129090, Moscow, RUSSIA FEDERATION

Phone: +7-095-737-7868 Facsimile: +7-095-737-7869
